

## CONTRIBUTIONS OF THE SCIENTISTS FROM CLUJ TO THE COSMIC SPACE RESEARCH

Dumitru RISTOIU<sup>1</sup>

<sup>1</sup>*Faculty of Environmental Science and Engineering, Babeş-Bolyai University,  
Cluj-Napoca, Romania.*

*\*Corresponding author: ristoitud@gmail.com*

**ABSTRACT.** It is now widely accepted that modern investigations for research of complex processes occurring in the atmospheres of the planets began on Oct. 4, 1957 with the orbiting of the Earth's first artificial satellite. With the launch of the first rockets and satellites in space, there are "unexpected" discoveries world-wide in this domain. Thus, in 1958, van Allen radiation belts around the Earth (Henry Elliot, 1959) were discovered, which led to the launch of laborious scientific programs for the study of Earth's Higher Atmosphere in all aspects (electrical, magnetic, chemical, etc.). Investigation of neutral and ionized constituents from upper atmosphere of the Earth represent an important parameter for solving some geophysical and astrophysical problems. For example, atmospheric pressure and temperature can not be accurately measured or determined without knowing very well the composition of the neutral constituents. The problem of locating the gas gravity separation level can only be solved only after a detailed investigation of the neutral atmosphere composition. Knowing the structure of the atmosphere is the basic requirement for investigation of other physical processes from the Earth atmosphere. The work is a history of the main investigating institutes from Cluj-Napoca who were involved in the initiation, development and construction of equipment for the major investigate the outer space and for conducting observations of trajectories of artificial satellites.

**Key words:** *INCDTIM, Calibrator, Mass spectrometer, Nano balance, Deuterium, Lunar soil, Soyuz 40.*

### INTRODUCTION

The mass spectrometers were used in the research laboratories as multi-purpose sensitive equipment capable of analyse quantitatively and qualitatively complex mixtures of gas, liquid and solid. It is not surprising that when high altitude missiles became available to research, mass spectrometers were sent to investigate the nature of the higher atmosphere.

In 1949, a mass spectrometer with magnetic field is built and installed on a V-2 type rocket, making the first measurement of the ratio between the numerical densities (particles/cm<sup>3</sup>) of helium and argon up to the altitude of 130 km (O'Day, 1954). In 1953, a Bennett radio-frequency mass spectrometer is installed on an Aerobee rocket, and in 1959 on the Soviet satellite Sputnik 3 (Townsend, J.V., 1954). After 1960, these types of instruments are more frequently used for the measurements of upper atmosphere composition (Schaefer 1963). Simultaneously with the exploring of Earth's atmosphere, mass spectrometers are successfully used to investigate other planets from the solar system (Spencer, 1971, Hoffman, 1979, Istomin, 1983) and to investigate the Earth's natural satellite.

In this context, at the working meeting from 15-20 November 1965 in Moscow, delegations from eight socialist countries, including Romania, decided to set up and launch the INTERCOSMOS Program in order to cooperate for the peaceful exploration and use of cosmic space. The INTERCOSMOS Program was a replica of the American Space Research Agency (NASA). In 1968, the Inter-ministerial Commission CRAS (Romanian Commission for Spatial Activities) was founded, in order to coordinate the development of space activities at national level.

The initiative of including new areas of space research among the scientific domains of researchers from Cluj belongs to: Professor Dr. doc. Victor Mercea, Corresponding Member of the Romanian Academy, Director of the Institute of Isotopic and Molecular Technologies from Cluj (now INCDTIM) and Professor dr. doc. Gheorghe Chiş, director of the Astronomical Observatory from Cluj, as a consequence of their participation at the annual meeting of the Cosmic Physics Group from the INTERCOSMOS Cosmic Space Research Program in 1971.

One of the conclusions of this meeting was the necessity of building new equipment for the study of Earth's atmosphere and for the ground monitoring of the satellites paths found on orbit. On this occasion Professor V. Mercea proposes to be introduced as a future research, in INTERCOSMOS Program, the topic of calibration improvement of mass spectrometers from spatial objects, and the development and construction of a quadrupole mass spectrometer, which proved his efficiency in the experiments performed by Western countries. Professor Gh. Chiş proposed the involvement of the Astronomical Observatory of Babeş-Bolyai University from Cluj in these research activities.

The main research institutions from Cluj-Napoca, which have been involved in the realization of these themes, were:

- Institute of Isotopic and Molecular Technologies (current Institute for Research and Development for Isotopic and Molecular Technologies – ITIM) and
- Babeş-Bolyai University from Cluj-Napoca through the Faculty of Chemistry and the Faculty of Mathematics (Astronomical Observatory).

Since 1993, the private company BITNET-CCSS Cluj-Napoca was also involved in different space research activities.

## RESEARCH ACTIVITIES PERFORMED AT ITIM CLUJ-NAPOCA

The participation of ITIM from Cluj-Napoca in the joint program for research and peaceful use of the cosmic space INTERCOSMOS began in 1972 by approaching two research topics regarding: (1) the mass spectrometers calibration during flight and (2) the construction of a quadrupole mass spectrometer for the research of Earth upper atmosphere.

### *Mass Spectrometer Calibration Device*

Starting from the need to calibrate mass spectrometers installed on space objects, which can modify their characteristics during space flight, a research topic has been proposed on "Developing of a method and building of a device for calibration during flight of mass spectrometers installed on satellites or orbital laboratories". The method used by Soviet specialists from the Moscow Cosmic Research Institute (I.K.I. - Moscow) consists in using the diffusion phenomenon of light gases through quartz membranes. The calibration gas should not be found among the atmospheric components which should be measured. Romanian specialists propose the replacing of the quartz membrane with a metallic membrane.

The device is composed of two distinct parts: a) the mechanical part, comprising the standard gas tank, the temperature sensor and the heating resistance of the tank; b) the electronic block providing the thermoregulation of the standard gas flow which pass through the stainless steel metallic wall, and it can be changed from the ground in two steps to  $10^{-2}$  and  $10^{-4}$  l/s and the sending of the data to telemetry system. The gas which comes out from the standard is directed to the ion source of the spectrometer which will be calibrated. The input time of the device is 5 minutes, consumes about 5 W and has a total weight of 0.7 kg. The operating principle is illustrated in figure 1 (Mercea Victor, 1975).

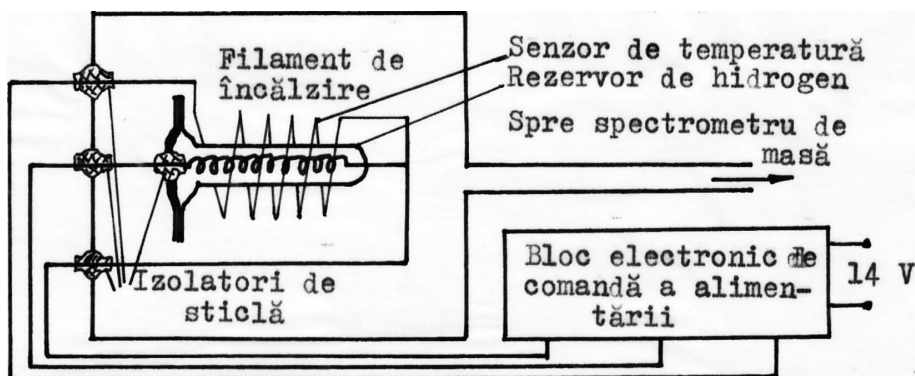

Fig. 1. Schematic diagram of a device for calibration of mass spectrometers during flight.

The first experiment with this device, called DESM-1, took place on the INTERCOSMOS-12 satellite launched on October 31, 1974 on the Plesetsk Cosmodrome located at 62.8 °N, 40.4 °E, figure 2.



**Fig. 2.** *The Cosmodrome from which the INTERCOSMOS 12 satellite was launched.*

The obtained results suggested the need to change the calibration gas due to the fact that over the mass spectrum of the calibrated gas, an unknown background spectrum is overlapping, which in some cases had very high values. Further research was carried out on the calibration method and on the instrument. Thus, DESM-3 uses deuterium as a filling gas, palladium membrane, has an entry regime time of one minute, consumes only 2.5 W and has a total weight of 0.150 kg.

Figure 3 shows the calibration curves of the two standard versions and a photograph of DESM-3.

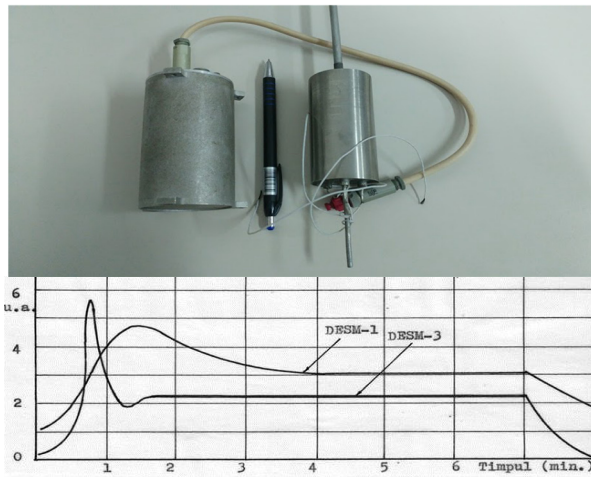

**Fig. 3.** *DESM-3 and the calibration curves of the two standards (entry regime time versus flux intensity) (Mercea, 1975).*

The DESM-3 device was installed on the INTERCOSMOS-18 satellite launched on October 26, 1978, on the Baikonur Cosmodrome, with great results. The weight of the device was reduced from 0.540 kg (DESM-1) to 0.125 kg (DESM-2) and power consumption from 9.2 watts to 6 watts.

**Quadrupole mass spectrometer for the research of the isotopic composition of the upper atmosphere**

The second research topic approached by ITIM Cluj-Napoca in 1972 was closely related to the diversification and improvement of mass spectrometry equipment. A radio-frequency mass spectrometer was installed and used for INTERCOSMOS. Other types of mass spectrometers have been successfully tested, worldwide, from which the mass spectrometers with magnetic field and quadrupole-type proved their performances. Starting from the advantages of the quadrupole mass spectrometers, compared to those with magnetic field, it was proposed to start the research activities in order to design a quadrupole mass spectrometer for the atomic and isotopic analysis of the major constituents of the upper atmosphere of the Earth.

The main advantages of this type of spectrometer are: low weight, high robustness, linear mass range, high sensitivity, low power consumption. Figure 4 shows a simplified scheme of the QMS-3 spatial mass spectrometer and in figure 5 it is shown its construction scheme (Ristoiu D., 1980).

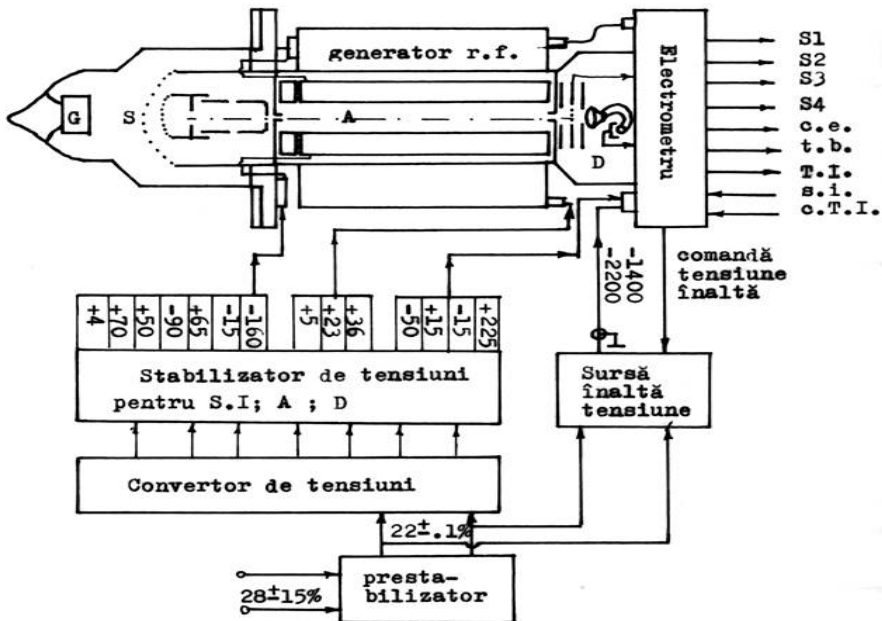
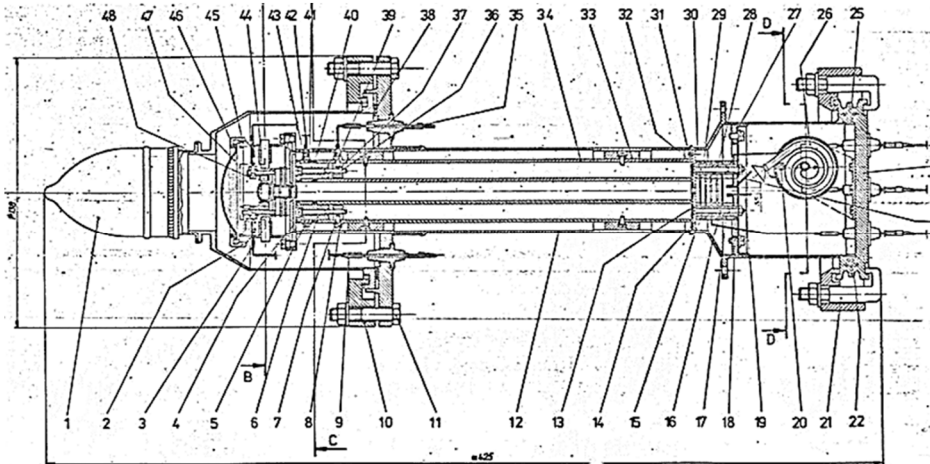

Fig. 4. Simplified diagram of quadrupole mass spectrometer with spatial destination and its electronic block (Ristoiu D., 1980).

The laboratory model of this instrument was put into operation in 1975 and has the following working parameters: the mass range 1 - 55 uam, resolution of 200 at 1/2 of the height of the mass peak, sensitivity of  $10^{-4}$  A / torr with Faraday collector and 1 A / torr with secondary electron multiplier, dynamic range  $10^6$  covered in 4 steps, maximum power consumption 20 W, total weight 12 kg.



**Fig. 5.** Scheme of construction of QMS-3 (Ristoiu D., 1980).

By redesigning some subassemblies of the apparatus, a technological model has been achieved that has a performance similar to laboratory model but consumes less power (15 W) and has a lower weight (7.5 kg), the mass spectrometer SMQ-1 was launched on the high altitude geophysical rocket Vertical 7 in November 3 1978 and worked well with the following flight performance: mass range 1-40 uam, resolution 100 at 1/2 of peak height, sensitivity of  $10^{-4}$  A / torr for Faraday collector and 1 A / torr for the secondary electrons multiplier, dynamic range  $10^5$ , average power consumption 12 W, total weight 6.3 kg.

The main atomic and molecular species detected in the mass spectra were:  $H^+$ ,  $H_2^+$ ,  $N^+$ ,  $O^+$ ,  $N_2^+$ ,  $O_2^+$  and as ground-based impurities  $H_2O^+$  and  $OH^+$ , figure 6 (Ristoiu D., 1980).

In order to improve the working performance of the device, for a new release, the ionic current detection system and the vacuum shutdown of the device were modified. For the technological and pre-launch samples the device was equipped with an own vacuum system based on an ion pump with a pumping speed of 10 l/sec. This version was called QMS-3. During the technological tests carried out at IKI-Moscow and the Cosmodrome in April 1980, the device proved to be reliable with substantially improved results (Todorean G., 1979). This type of spectrometer was launched on VERTICAL 9 and 10 rockets.

Figure 7 shows the standard container on which was installed the scientific equipment on VERTICAL rocket (top left) and fly version of QMS-3 (bottom left-electronic block and right-mechanical side).

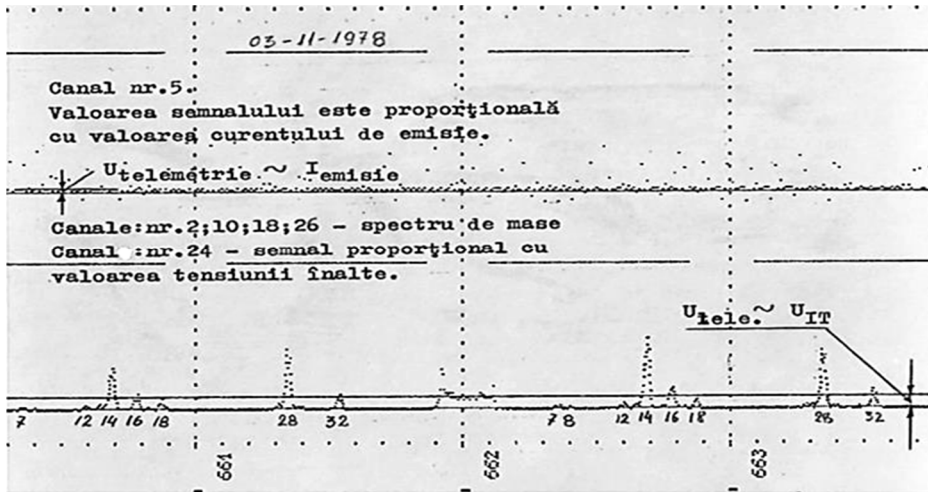

Fig. 6. Two-channel recording sequences.



Fig. 7. Mass Spectrometer QMS-3. The electronic block (bottom left), the container (top left) and the mechanical part of the QMS-3 (right) on which is installed the radio frequency generator and the electrometer.

The success of this experiment, designed and built entirely at ITIM and successfully launched in space, places Romania among the top six countries in the world that build mass spectrometers for space research. The team's success was rewarded by awarding the Gold medal to the QMS-3 spectrometer at the Moscow National Exhibition of Achievements of the National Economy 1987, for "Cuadrupolar Mass Spectrometer for Spatial Applications" Figure 8.



Fig. 8. Gold medal, assigned by Decree 416-N / 03.iunie 1987 Certificate Number. 1599, at the "National Economy Exhibition" USSR, Moscow.

## MARS '94 PROGRAM

It was launched in February 1987. ITIM Cluj-Napoca participates with two experiments

1. "Study of the structure and isotopic composition of the high atmosphere of Mars using mass spectrometry", abbreviated **SCIAPM**. The purpose of the experiment was to obtain global information about the concentrations of neutral and ionized constituents and their isotopic ratios in the high atmosphere of Mars

2. Piezoelectric Hygrometer



### The SCIAMP experiment

In the case of Mars, as well as in the case of the other planets, the knowledge of the atmosphere composition and especially of isotopic ratios is very useful for the explanation of the genesis and evolution of the atmosphere. The importance of the physical and chemical processes which are playing a major role in the state of the atmosphere, can be obtained by isotopic data.

The mass spectrometry is the most important and versatile method for isotopic - ratios measurements (Prolss, 1974, Mercea V, 1978). Taking account of the accuracy of double collector methods, used for the mass spectrometer isotopic analysis, a device consisting of twin quadrupole mass spectrometers is proposed (Ristoiu, 1991).

The use of mass spectrometers devices in the planetary missions was very useful for the study of planetary atmospheres of the Earth, Venus, Mars and Jupiter (Surkov 1957). The device consisting in the use of the double collector method was realised by the simultaneous use of a pair of quadrupole mass spectrometers. Such a mode of operation of the device can resolve some problems like those appearing in the case of quick commutation of the range of ionic current measuring systems, quick temporary variations of the pressures and bulk variations of the electronics.

The geometry of the twin quadrupole mass spectrometers is identical.

In order to tune one of the cuadrupolar mass spectrometer on the mass  $m$  a potentials  $\pm(U + V \cdot \cos\omega t)$  are applied on the rods of mass analyser. For given  $a$  and  $q$  — operating parameters — the magnitude of  $U$  and  $V$  can be deduced from the relations [7]:

$$a = \frac{8eU}{mr_0^2\omega^2} \quad q = \frac{4eV}{mr_0^2\omega^2}$$

In these relations:  $e$  - electron charge,  $r_0$  - radius of the quadrupole field,  $\omega$  - operating frequency of the mass analyser. For the tuning of the other quadrupole mass spectrometer, on the mass  $m + k$  the potentials  $(U' + V' \cos\omega t)$  must have  $U' = U(1 + k/m)$  and  $V' = V(1 + k/m)$ .

Until the contributions of the ions having masses  $m + k - 1$  and  $m + k + 1$  does not give remarkable contributions to the peak of the ions of mass  $m + k$ , one can decrease the mass resolutions in order to obtain higher ionic currents. The operations of device is done and controlled by micro computerized electronic unit.

After the dissolution of the Soviet Union in 1991 the project was abandoned. The construction of the device is presented in Fig 9.

### The Piezoelectric Hygrometer experiment

The working principle of this device consists of changing the fundamental frequency of vibrating piezoelectric quartz crystal, when a change of the mass of a thin film deposited on its surface, occurs. Such a change of the film mass may be obtained by absorption of gasses or vaporous which are present in the quartz crystal monitor environment. The piezoelectric hygrometer consists of such a quartz crystal covered with a thin hygroscope layer. This quartz crystal drives the frequency of an oscillator, which may be measured at the output, with a digital frequency meter.

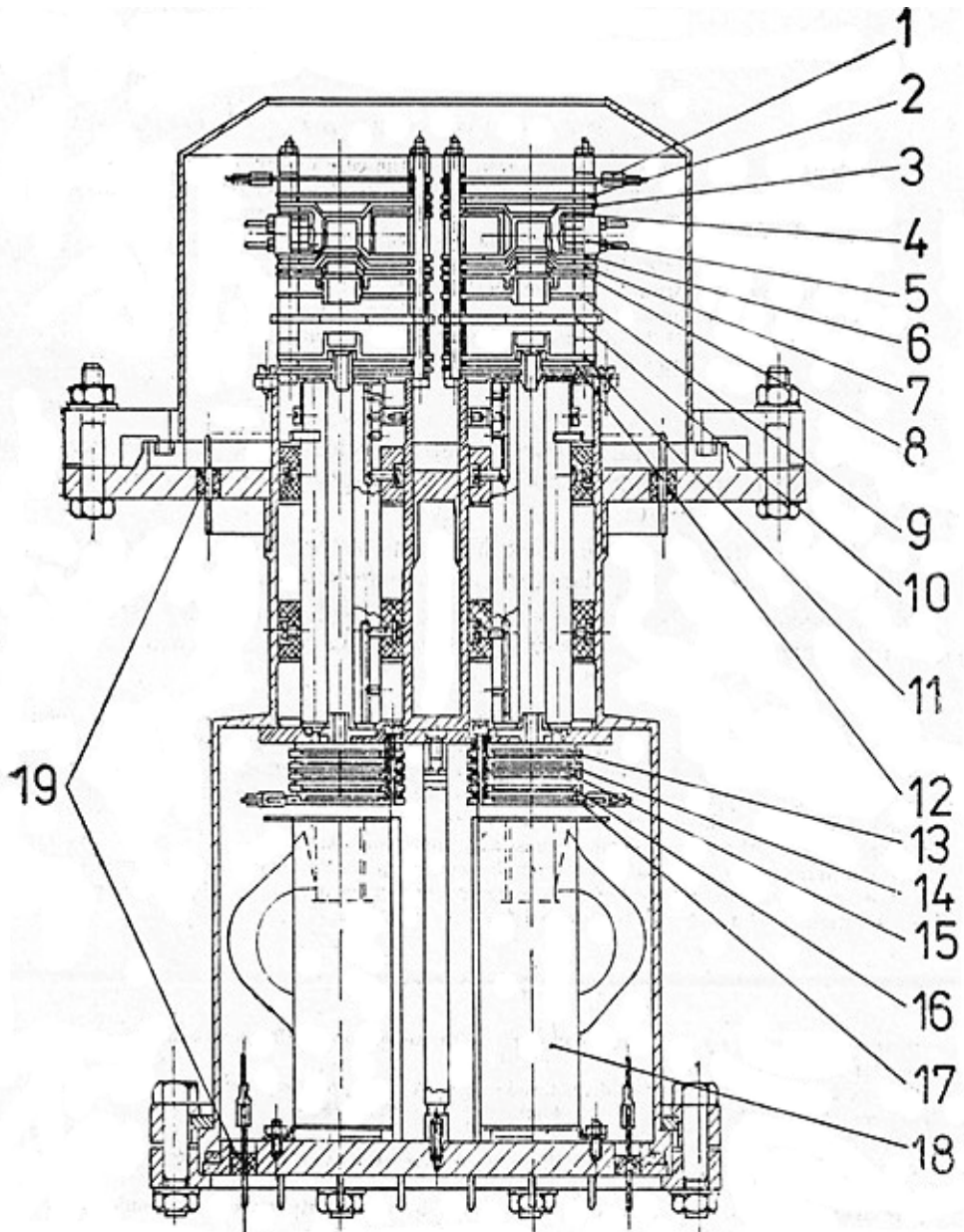

**Fig. 9.** The MARS '94 spectrometric device. 1, 2, 3 — grids, 4 — electron lens, 5 — filament ensemble, 6 — ionization chamber, 7 — extraction grid, 8,9 — ion lens, 10 — retarding potential analyser, 11 — total ion current collector, 12 — entrance aperture, 13, 15, 17 — screen grids, 14, 16 — ion collector grids, 18 — channeltron electron multiplier, 19 — feedthroughs (Ristoiu 1991).

In order to overcome the unwanted effects, mainly that of the temperature, on the quartz crystal frequency, the addition of an identically quartz - oscillator system, having an uncovered reference quartz, is proposed. The measured signal will be the electronically operated frequency difference between the two quartz crystals.

Performances: Measuring range: 1 - 30,000 ppm water, (unlinear, more sensitive at lower concentrations); Working temperature range: -40 - + 80 °C; Power consumption: - 1 Watt; Weight: - 500 g.

## **ANALYSIS OF SOIL SAMPLES FROM THE MOON**

Taking into account both the equipment from the Mass Spectrometry Laboratory at ITIM Cluj-Napoca and the methodology for physico-chemical analyses, since 1974, a new research topic was studied that proposed "The study of the gases in samples of lunar soil". For this, the Soviet side provided the ITIM scientists with 0.5 grams of lunar soil samples that were analysed in order to determine the content of rare gases. To perform these analyses, an installation for the extraction of gas from the samples was designed and a method of static analysis of the gases contained in the soil samples was elaborated. Of particular significance from the point of view of the planet's genesis is the ratio of the isotopes of Argon:  $^{40}\text{Ar}$  (99.6%),  $^{36}\text{Ar}$  (0.34%) and  $^{38}\text{Ar}$  (0.06%). The obtained results confirmed the common origin of the Moon and Earth soil.

## **EXPERIMENTS PROPOSED BY THE ROMANIAN COSMONAUT DUMITRU PRUNARIU ON THE SOYUZ-40**

### ***Nano-balance***

Since 1974, a new theme has been dealt regarding the development of an instrument for the determination of humidity in planetary atmospheres in order to detect water traces from other planets atmosphere. The device was based on a very sensitive piezoelectric balance capable of detecting water in quantities of up to  $10^{-9}$  grams. It was originally designed to measure the water vapour content of the Mars or Venus atmosphere in 1975. Due to the short term, the destination of the experiment was changed. Later, this microbalance was perfected and proposed as an experiment at the Soyuz-40 orbital station with a Romanian cosmonaut on board, in order to study the erosion of protective layers under cosmic conditions; the experiment was "NANOBALANCE".

In principle, the instrument consists of two piezoelectric resonators installed on the same crystal, from which one is subjected to cosmic agents. Frequency changes resulting from the change in mass of the investigated protection layers are recorded and sent to the ground.

The purpose of the experiment was to obtain information on the stability of thin silicon dioxide protective layers under the influence of the cosmic environment (radiation, vacuum, etc.). In this way, it can be seen how long resist a thin layer of silicon dioxide deposited on the surface of some optically active elements located outside the space laboratories, such as solar cells. Such layers have a remarkable chemical resistance and have the advantage of being transparent in a very wide spectral range.

The research apparatus that served to NANOBALANCE experiment weighs with high precision and very high sensitivity of 10 ng, the mass of a thin layer deposited on the surface of the sensor made up of a quartz resonator. The degradation of this thin layer of silicon dioxide translates into the modification of the vibration frequency of the quartz resonator, which is measured by the apparatus and then is transmitted to the Earth.

The experiment was carried out by exposing the sensor to the cosmic environment for a specified time, after which, at a command sent by the cosmonaut, the sensor closed and the frequency change occurred as a result of the cosmic action on the protective layer of the dioxide silicon.

In addition to the autonomous block, the device also includes a command and control board used by the cosmonaut.

By implementing the NANOBALANTA technological experiment, particularly useful results were expected that could reduce the weight of solar cells and prolong the duration of their use by applying thin layers of silicon dioxide on their surface.

### ***DEUTERIUM experiment***

Global measurements with mass spectrometers installed on spatial objects reveal large discrepancies between the results obtained by different groups of researchers. In order to discover the nature of these discrepancies, it was proposed to produce a quadrupole mass spectrometer, type QMS-3, equipped with two calibration devices which could be operated alternately during flight by the cosmonaut. One of the standards will use hydrogen and the second will use deuterium. In this way one can study the systematic and memory errors of space-mass spectrometers.

The research team proposes to test the SMO-3 quadrupole mass spectrometer under real working conditions for its usage in measuring the ratio of hydrogen isotopes to a reference unit. Direct measurement of atomic hydrogen is difficult due to its very high chemical reactivity. Various experiments mentioned abnormal hydrogen behaviour and an H / D ratio very different from the one known on the ground.

In order to correct the results obtained by direct measurements it was proposed to study the photochemistry and recombination reactions of H and D in the ion source of the spectrometer under evolution conditions of spectrometer on a spatial object. Aspects of Romanian Cosmonautics visit to Cluj Napoca are shown in Figures 10 and 11.



**Fig. 10.** *Visit of Cosmonaut Dumitru Prunariu at ITIM 1983.*



**Fig. 11.** *Visit of Cosmonaut Dumitru Prunariu at UBB, 2014.*

Measuring the isotopic distribution of hydrogen versus the altitude provides first of all information on hydrogen dynamics and secondly information on the origin and genesis of hydrogen on Earth.

Due to the complexity the required equipment, the experiment could not be finished on time.

## RESEARCH ACTIVITIES PERFORMED AT UBB CLUJ-NAPOCA

**Faculty of Chemistry.** In 1978 Prof. dr. Emil CHIFU proposes the topic: The superficial liquid leakage in the absence of gravity, to be carried out in collaboration with the NASA - National Aeronautics and Space Administration - USA. Theme consisted of two experiments; a) The surface leakage between the two surfaces joined by shallow channels; b). Superficial leakage on a liquid drop. After a rigorous selection process by NASA, the two experiments had been accepted to be tested in outer space (Tomoaia-Costișel, 2007).

It is very interesting that although the teacher Chifu - which, for reasons unknown, was not allowed to leave the country, although he was always invited by NASA to participate in the realization of his project - he keep in touch (through the post office) with the Jet Propulsion Laboratory team of researchers that built the experiment model and implemented on DDM (Drop Dynamics Module) module in NASA's 3rd Lab Space Lab 3 (1981).

**Faculty of Mathematics.** The Astronomical Observatory is an educational and research institution in fields such as general astronomy, astrophysics, celestial mechanics, and artificial satellites.

Satellites are very complex machines that require precise mathematical calculations in order for them to function. There are number of scientific reasons for wishing to have an easily visible satellite. In particular, precision orbit determination will probably be done optically, and it is clearly desirable to have a satellite which reflects or emits a considerable amount of light. An available method is the creation of a large reflecting object such as a metal balloon, Figure .13.

Precision orbit determinations based on optical tracking can be used for: a) Determination of air drag at high altitudes, from which atmospheric density can be derived, b) A possible complication is the effect of an electrostatic charge on the satellite, and the interactions between this charge, the ions present in the ionosphere, and the Earth's magnetic field, c) Geodesic measurements on the size and shape of the Earth, d) Ion densities, when coupled with certain precision radio techniques.

The launch of Earth's artificial satellites, started in 1957, opened new possibilities for collaboration to the Cluj-based astronomy. The two satellite tracking and observation stations in Cluj and Bucharest begin close collaboration with similar research centres like the USSR and the US.

The college of researchers at the Astronomical Observatory of UBB (Faculty of Mathematics) takes part in making systematic observations on the “brilliant” satellites Echo I and Echo II, as well as on the cosmic triangulation operations carried out between 1963 and 1964.



**Fig.12.** *Pageos, balloon satellite.*



**Fig. 13.** *Astronomical Observatory of UBB.*

With the launch of the INTERCOSMOS Program, the activities of the team extend to the observation and tracking of the “brilliant” satellites launched by the USSR.

### **RESEARCH ACTIVITIES PERFORMED AT BITNET-CCSS CLUJ-NAPOCA**

**BITNET-CCSS** is a small private company, which is active since 1993 in the field of technological research & consulting.

Main research and business areas: applications of satellite communications, small radiotelescopes, prototype surveillance of space sensors (optical and radio) and information technology.

BITNET is involved in the development of the Romanian space program and has completed more than 50 R&D projects until today, many of them in partnership with Romanian authorities, universities, research institutes or other companies. BITNET is involved in space related international projects and activities, including cooperation with ESA and NATO. The figure 14 show a part of infrastructure of Company.



**Fig.14.** Our test infrastructure for satellite communication and surveillance of space experiments – in development. Located in Marisel, 1150 m altitude, 50 Km far from our offices in Cluj-Napoca. Electromagnetic quiet zone and without light pollution. The test bed hosts BITNET’s astronomical observatory and several antennas covering different radio bands, from few Hz to 13 GHz

## REFERENCE

- Henry E., 1959, The van Allen radiation belts, its possible origins. *The New Scientist*, **5** (125), pp. 787-790.
- Hoffman J.H., Hodges R.R Jr., McElroy M.B., Donahue T.M., Kolpin M., 1979, Composition and Structure of the Venus Atmosphere: Results from Pioneer Venus. *Science*, **205**, pp. 49-52.
- Istomin V.G., Gretchnev C.V., Kotchinev V.A., 1983, Venera -13 and, Venera-14 Mass spektrometria atmosferî. *Kosm. Issled.*, **21**, pp. 410.
- Mercea V., Ardelean P., Ioanoviciu D., Pamula A., Ursu D., 1978, *Introduction in mass spectrometry*, Technical Editure, Bucharest.
- Mercea V., Istomin V.G., Chereji I., Todorean G., Ristoiu D., 1975, Calibrator for space flight mass spectrometers. *Rev. Roum. Phys.*, **20**, pp. 839.
- Muscă A., 2012, *Dumitru Dorin Prunariu biography of a cosmonaut*, 304 p., S.C. Adevărul Holding, ISBN 978-606-644-04107.



- O'Day M.Q., Boyd R.L.F., Seaton M.J., 1954, *Rocket Exploration of the Upper Atmosphere*, p.1, Pergamon Press, London.
- Pross G.W., Zahn U. von, 1974, Esro-4 Gaz analyser results. 2. Direct measurements of changes in the neutral composition during an ionospheric storm. *J. Geophys. Res.*, **79**, pp. 2535.
- Ristoiu D., 1980, The study of the isotopic composition of the upper atmosphere of Earth by mass spectrometry technique, Doctoral thesis, Babeş-Bolyai University, Cluj-Napoca.
- Ristoiu D., Ursu D., Luşsa N., Gligan N., Istomin V.G., 1991, Isotope analysis of Mars gaseous components. *Studia Univ. Babeş-Bolyai, Physica*, **XXXVI**, p1.
- Ristoiu D., 2005, *Fizica Mediului – Atmosfera* (in Romanian), Ed. Napoca Star, Cluj-Napoca, ISBN 973-647-268-X.
- Schaefer E.J., 1963, The dissociation of oxygen measured by a rocket-borne mass spectrometer. *J. Geophys. Res.*, **68**, pp. 1175-1176.
- Spencer S.N.W., 1971, Upper Atmosphere Studies by Mass Spectrometry. *Adv. Mass Spectrometry*, **5**, pp. 509.
- Surkov Iu.A., Ivanova V.F., Pudov A.N., Sheretov A.P., Kolotilin B.I., Safonov M.P., Toma R., Izraeli G., Lespagnol J., Imbo D., Ozer A., Caramel D., 1957, Opredelenie Himiceskogo Sostava Aerozolia Oblatchinogo Sloia Veneri na AMS VEGA-1 Mass Spektralnoi Apparaturai MALAHIT, *Kosm. Issled.*, **25**, pp. 744.
- Todorean G., Ristoiu D., Mercea V., Istornin V.G., 1979, Quadrupole Mass Spectrometer Launched on Geophysical Rocket "Vertical 7". *Rev. Roum. Phys.*, **24**, pp. 685.
- Tomoaia-Cotişel M., Chifu A., 2007, "In Memoriam Professor Emil Chifu - (1925- 1997)". *Studia Univ. Babeş-Bolyai, Chem.*, **52** (3), pp. 3-5.
- Townsend J.V.jr., Meadows E.B., Raket, 1954, *Exploration of the Upper Atmosphere*, Ed. Boyd R.L.F., Seaton M.J., Pergamon Press, London, p.169.

