

Static and dynamic tests at a railway tank wagon

Tiberiu Stefan Mănescu, Nicusor Laurentiu Zaharia*, Constantin Ioan Barbița

Railway tank wagons are widely used for the transportation of liquid cargo as petroleum products, acids, alcohol etc. During the last years only tank wagons with bogies were manufactured (four axles wagons). The prototype of each wagon's series is tested according with international standards in purpose to validate the design (the project). This paper present the static and dynamic test performed at the body of a four axles tank wagon.

Keywords: tests, tank wagon, body, stress, strain

1. Stress calculation based on strains measurement.

Stress occur in the structures due the efforts. With the help of strain gauges glued on a structure we ca measure strains when an effort (force or moment) is applied. The strain measured with a strain gauge can be transform in stress with Hooke's law [1]:

$$\sigma = E \cdot \varepsilon \quad (1)$$

where σ is the stress, E is Young modulus and ε is the measured strain with the strain gauge. The strains measured with a rosette (0° - 45° - 90°) can be transform in stress with above equations [1]:

$$\sigma_1 = \frac{E}{2(1-\nu)} (\varepsilon_A + \varepsilon_C) + \frac{E\sqrt{2}}{2(1+\nu)} \sqrt{(\varepsilon_A - \varepsilon_B)^2 + (\varepsilon_C - \varepsilon_B)^2} \quad [N/mm^2] \quad (2)$$

$$\sigma_2 = \frac{E}{2(1-\nu)} (\varepsilon_A + \varepsilon_C) - \frac{E\sqrt{2}}{2(1+\nu)} \sqrt{(\varepsilon_A - \varepsilon_B)^2 + (\varepsilon_C - \varepsilon_B)^2} \quad [N/mm^2] \quad (3)$$

$$\sigma_{ech} = \sqrt{\sigma_1^2 + \sigma_2^2 - \sigma_1\sigma_2} \quad [N/mm^2] \quad (4)$$

where σ_1 is the principal stress 1, σ_2 is the principal stress 2, σ_{ech} is von Mises equivalent stress, E is Young modulus and ε_A , ε_B , ε_C are the measured strains with the rosette and ν is Poisson ratio.

2. Sensors setup

Strain sensors (strain gauges and rosettes) are glued on the structure (body) of the wagon based on finite element analysis and/or experience of the of the test experts. The setup of the sensor is important for each test's objective according with the standard [2], [3].

2.1. Sensor setup for static tests.

For the static tests, strain gauges and rosettes were mounted for strains measurements and stress calculation. The forces were measured with force cells and the deformation of the body under loads were measured with displacement transducers.

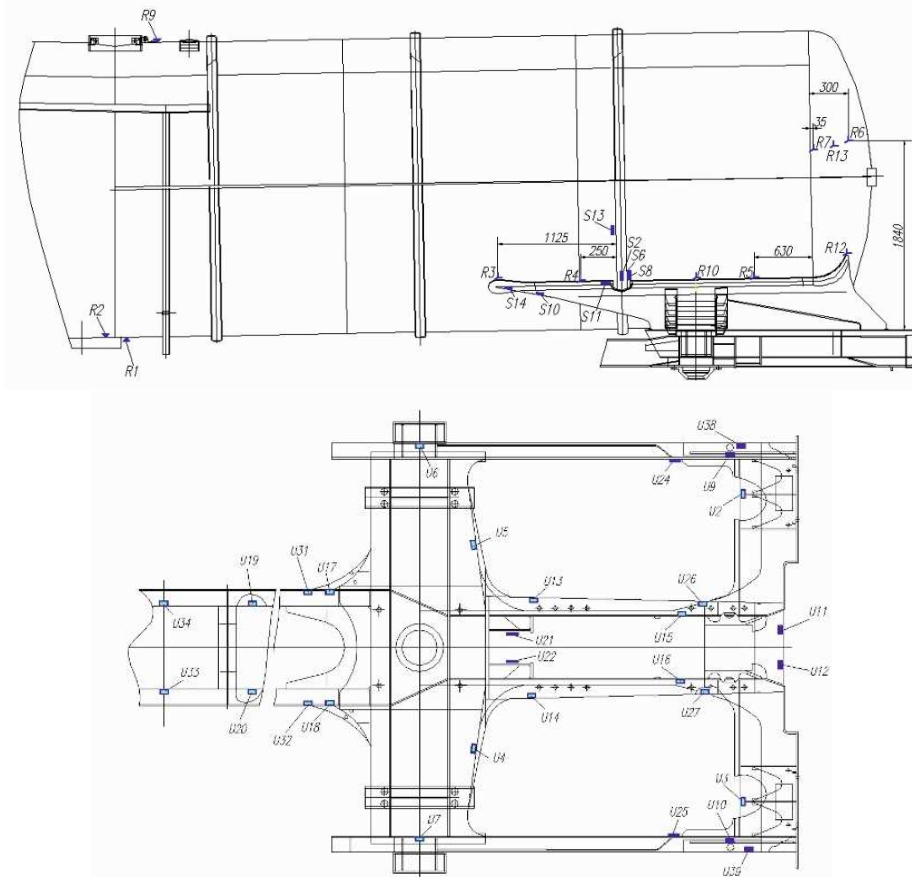

Figure 1. Strain gauge and rosettes layout.

2.2. Sensor setup for dynamic test.

For the dynamic tests (impact tests), strain gauges and rosettes were used for strains measurements and stress calculation. The impact forces under buffer's plate was measured with load cell, the acceleration in longitudinal direction was measured with an accelerometer. The impact speed was also measured.



Figure 2. Force cell and accelerometer.

3. Tests

Before the tests, numerical studies with finite element method were done. Those studies were the starting point of some of strain gages locations [4]. The finite element analysis software used was ANSYS [7]. At this moment, the finite element method is widely used all over the world by the designers, but is far to be perfect; because of its limits it is necessary that virtual experiments to be confirmed by real experiments. But still, finite element method is one of the most powerful tools used in design stage or when the necessity to modify the body of the prototype vehicle when some unconformities appear due the testing or because some last moments client requirements [8]. During the years, the observations proved that none of the testing methods (virtual or real) it is not a panacea (a combinations of the methods is recommended), at that moment the real tests are the key (or decision element) to prove the conformity or not of a product with reference documents (standards, technical specifications etc.).

Experimental stress analysis with strain gages for the tank wagon was performed in Romanian Railway Authority AFER's Rolling Stock Laboratory (RENAR accredited laboratory) as follows:

- Static tests on AFER's static test bench from Bucharest;
- Dynamic ramming at AFER's Railway Testing Center from Făurei.

Experimental stress analysis with strain gages for wagons is made according with [9], [10]. European Normative 12663 was fundamentally changed in 2010 (even if modification draft was from 2007) regarding to the first version from 2000. Since

2010, the standard has two parts, the first is for passenger coaches and locomotives and the second part is for the wagons. Regarding the second part, there are similarities between the EN 12663 and ERRI B12/RP 17 and ERRI B12/RP 60 especially to the classifications of elements joints (welded) commonly founded at railways applications used to make an evaluation of vehicle body fatigue during life time, based of static tests.

3.1. Static tests and results.

The static tests performed to the tank wagon were [10]:

- Horizontal forces:
 - Tensile test at couple level with 1500 kN (TA);
 - Compressive test at couple level with 2000 kN (CA);
 - Compressive test on buffer's axe with 2 x 1000 kN (CT);
 - Compressive test on buffers at 50 mm below buffer's axe level with 2 x 750 kN (CT50);
 - Diagonal compressive test with 400 kN (CDD right and CDS left);
- Vertical loads (according with technical specification of the wagon):
 - vertical load test (V1) normal load;
 - vertical load test (V2) exceptional load;
 - lifting of the wagon at one end (RID);
 - lifting of the wagon (RID4)
- Combined loads:
 - tensile test at couple level combined with vertical load V1 (TA+V1);
 - compressive test at couple level combined with vertical load V1 (CA+V1);
 - compression buffer's axe test combined with vertical load V1 (CT+V1).

Horizontal forces were applied with hydraulic installation of the test bench at one end of the wagon and creating reactions at the other end of the wagon. Vertical loads were created loading the tank with water.

The measured stress with strain gauges in N/mm², must be smaller [10] than these indicated in the next table.

Table 1. Permissible stress for Chassis material: S355J2G3

Horizontal forces, lifting and combined loads limits (σ_{aH})		Welding free area 355	Welding area 323
Vertical loads (σ_{aV})	Class	A 277	
		B 150	
		C 133	
		D 110	

For rolling stock applications, strain gages with 10 mm measuring base are recommended but from our experience we can tell that also strain gages with 6 mm measuring base can be used. Because the body of the wagon is made from steel, Y series strain gages were used for general purpose. The electrical nominal resistance of Y series strain gages for railway applications is 120Ω because the strain gages it is a simple resistor [10]. As a measuring method experimental stress analysis with strain gages is very interesting because is an indirect measuring method: the strains from the wagon's body are transformed in an electrical resistance variation (because the strain gage is glued on the body) and from the variation of electrical units are transformed on a mechanical unit. In the next table are presented results for some strain gauges for horizontal and vertical loads.

Table 2. Results for some strain gauges (SG)

SG	σ_{aH}	σ_{aV}	CA	CT	CT50	TA	CDD	CDS	RID	RID4	V1
S1	309	110	10	17	15	-2	23	-18	0	9	-5
S2	355	277	-117	-172	-129	2	-85	22	128	-156	-55
S3	309	110	9	11	8	-9	3	-2	-12	-3	-6
S4	355	110	-12	2	2	10	0	1	6	5	-18
S5	309	110	-21	-4	-4	12	-2	1	4	2	-12
S6	309	110	-20	-38	-29	17	-20	7	26	-39	-15
S7	309	110	7	81	72	-7	87	-57	-176	77	11
S8	309	110	-5	-6	-6	9	2	-5	30	-12	-24
S9	355	277	-128	-186	-144	103	-68	-5	339	47	15
S10	355	277	-93	-126	-94	75	-51	8	132	-49	-13

3.2. Dynamic test and results.

Ramming tests simulate shock due sorting in marshaling yard. Shocks with empty wagon and loaded wagon were performed. The purpose of the shock test with empty wagon is that after the test, the functionality of the wagon not be affected, so no strains or stress in wagon's body are measured.

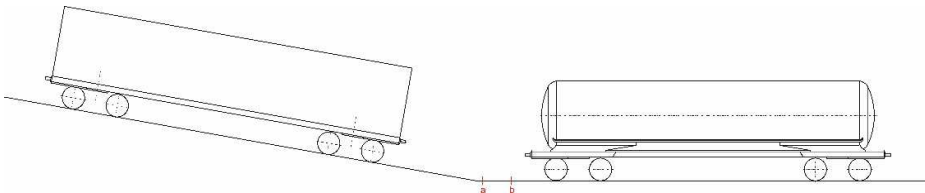

Figure 3. Ramming of the tank wagon.

The dynamic tests with empty or loaded wagon were performed as follows:

- The tank wagon was empty or loaded at maximum axle load;
- The tank wagon, placed in straight and level line was rammed by a ramming wagon fitted according with ERRI B12/RP17 report, chapter 3.1 (see figure 3);
- 40 shocks were done and maximum and residual strains were measured. With the help of Microsoft Excel, the trend of cumulated residual strains \mathcal{E}_{rc} was observed. The tests were performed at Fåurei Test Center.

Below in the figures is presented the evolution of different measured parameters, and the numerical results are presented in tables 3 and 4.

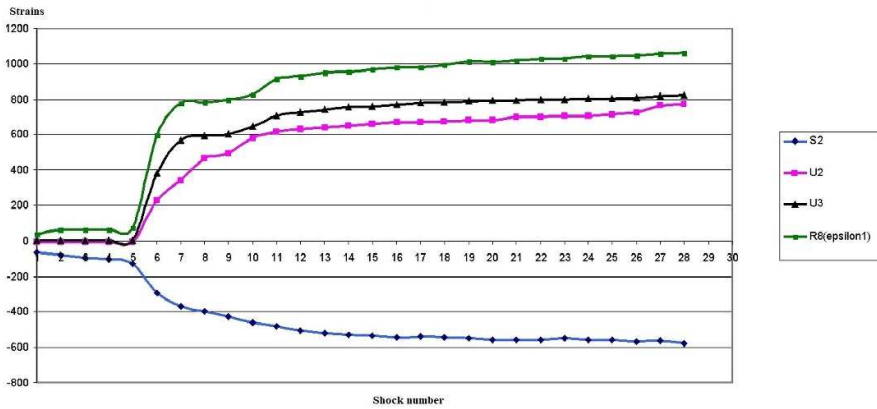

Figure 4. Strains evolution.

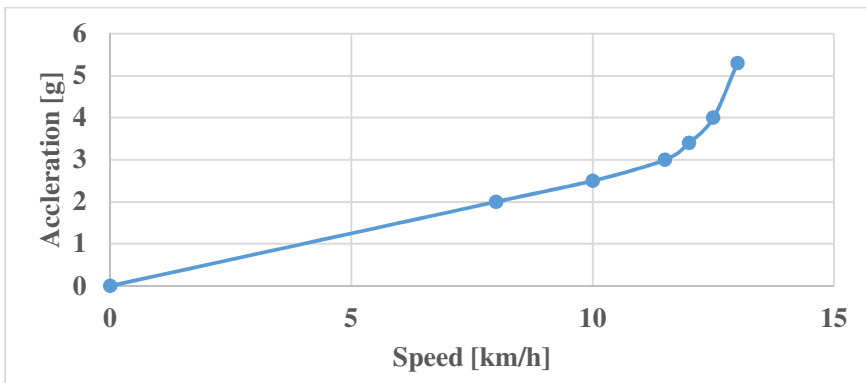

Figure 5. Acceleration versus speed.

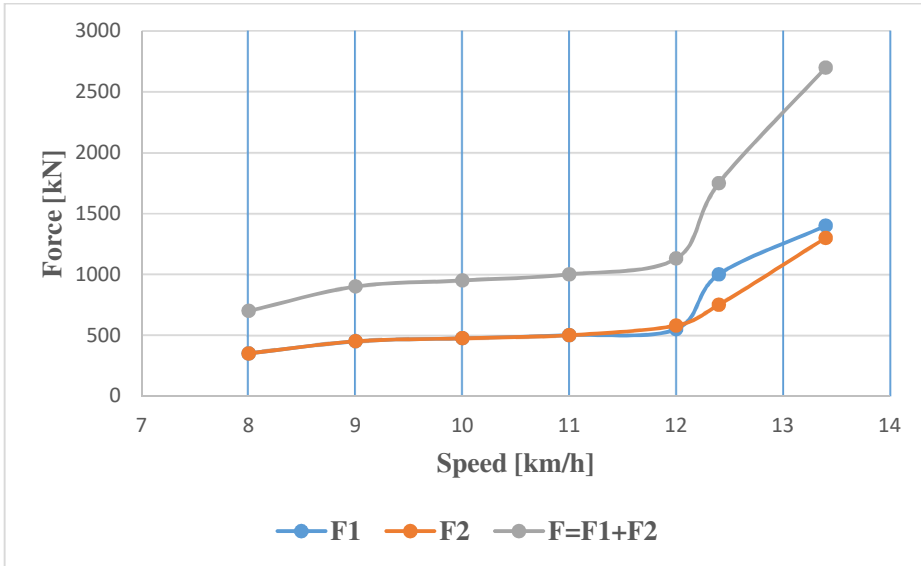

Figure 6. Force on buffers versus speed.

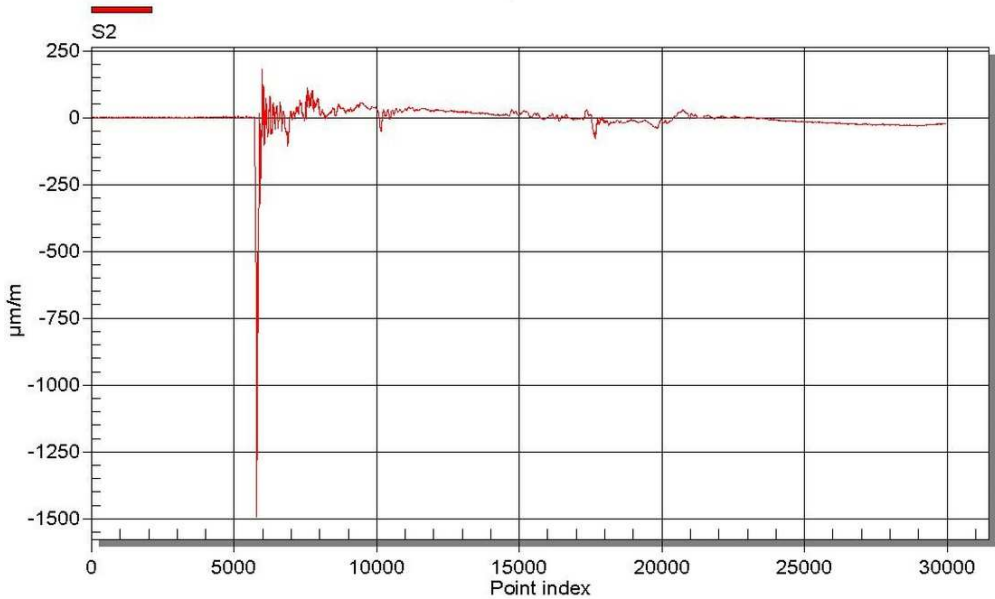

Figure 7. Strain evolution during a shock for S2 strain gauge.

Table 3. Results for some strain gauges (SG)

Shock number	5		10		15		20	
V km/h	12.16		12.00		12.08		11.92	
	σ_{\max} N/mm ²	ϵ_{rc} $\mu\text{m/m}$	σ_{\max} N/mm ²	ϵ_{rc} $\mu\text{m/m}$	σ_{\max} N/mm ²	ϵ_{rc} $\mu\text{m/m}$	σ_{\max} N/mm ²	ϵ_{rc} $\mu\text{m/m}$
S2	-232	-4	-194	-30	-200	-53	193	-49
S3	-9	5	-8	8	-8	10	-8	11
S9	-80	-10	-71	-29	-71	-24	-69	-25
S14	-89	17	-73	4	-74	-2	-69	-3
S15	-69	1	-49	-2	-50	-1	-44	2
S16	-172	-26	-151	-45	-155	-62	-153	-65
U2	171	-7	153	-5	148	-5	148	-6
U3	222	12	190	13	189	13	184	11
U26A	-88	-55	-84	-66	-81	-66	-82	-84
U27A	-179	66	-153	62	-156	65	-152	57

Table 4. Results for some strain gauges (SG)

Shock number	25		30		35		40	
V km/h	12.04		11.88		12.08		12.08	
	σ_{\max} N/mm ²	ϵ_{rc} $\mu\text{m/m}$	σ_{\max} N/mm ²	ϵ_{rc} $\mu\text{m/m}$	σ_{\max} N/mm ²	ϵ_{rc} $\mu\text{m/m}$	σ_{\max} N/mm ²	ϵ_{rc} $\mu\text{m/m}$
S2	-203	-59	-233	-52	-236	-62	-229	-91
S3	-8	12	-9	13	-9	17	-9	18
S9	-71	-27	-84	-27	-87	-34	-82	-53
S14	-71	-10	-83	-8	-86	-13	-82	-28
S15	-41	6	-51	16	-72	28	-67	18
S16	-160	-73	-180	-69	-185	-71	-180	-100
U2	151	-6	163	-8	167	-7	159	-7
U3	189	7	212	5	216	5	213	3
U26A	-85	-101	-92	-98	-92	-109	-89	-103
U27A	-157	51	-173	49	-177	38	-176	41

4. Conclusion

The tank wagons are widely used by railway freight operators to load and transport products like oil, gases, crude oil, mineral and vegetal oils, acids, alcohol, bitumen, water etc.

The results calculated with finite elements method are used useful in design stage or as previous stage of experimental stress analysis. The finite elements analysis was performed step by step: for example, if the thickness of the tank is smaller with 50% than initial, the tare of the wagon is 30% smaller than initial. The results confirm that such hard modification is possible, because the von Mises stress and displacements are smaller than allowable stress and deformations.

Experimental stress analysis with strain gages offer accurate measured results of an existing stress from a wagon's body when external forces are applied. Because is non-destructive measuring method, the test can be repeated. The accuracy of measuring devices is extremely high and it is validated by calibration with special calibrator devices or precision resistors. The experimental results, can be also used in purpose to validate finite element analysis results or as feedback for numerical model.

Based on test results, the designer can improve his design to increase the quality of the final product.

There is a correlation between the symmetrical measuring points, but differences appear during tests.

The explanations of the results can be:

- the wagon structure is not entirely symmetrically (dimensional tolerances are allowed for the chassis elements);
- the measuring points are not exactly at the same coordinates (minor differences appear during strain gages gluing);
- the forces are not applied symmetrically, because the longitudinal axe of the wagon is not coincident with railways axe (because of rail gauge).

References

- [1] Mănescu T.Ş., Jiga G.G., Zaharia N.L., Bîtea C.V., *Noţiuni fundamentale de rezistenţa materialelor si teoria elasticităţii*, Editura Eftimie Murgu, Reşiţa, 2010.
- [2] Tripa P., *Metode mecanice pentru determinarea deformaţiilor şi tensiunilor mecanice*, Editura Mirton, Timişoara, 2010.
- [3] Barbinta C.I., Tufisi C., Hamat C.O., Nedelcu D., Gillich G.R., Sensitivity analysis for frequency-based prediction of cracks in open cross-section beams, *Vibroengineering PROCEDIA*, 27, 2019, pp.7-12.

- [4] Mănescu T.S., Zaharia N.L., Avram D.S., Țigănașu N.M., *Nonlinear finite element analysis used in at tank wagons*, Proceedings of the 4th WSEAS International Conference on Finite Differences - Finite Elements - Finite Volumes - Boundary Elements, pp. 110-113, World Scientific and Engineering Academy and Society (WSEAS) Stevens Point, Wisconsin, USA, 2011.
- [5] Mănescu T.S., Zaharia N.L., Avram D.S., Țigănașu N.M., *Experimental stress analysis on a wagon model for railway vehicles*, Advances in Control, Chemical Engineering, Civil Engineering and Mechanical Engineering, European Conference of Mechanical Engineering, Puerto De La Cruz, Tenerife, Nov. 30- Dec. 2, 2010, pp. 19-21.
- [6] Capek J., Malkovsky Z., *Experience with the Testing of Railway Vehicles according to the European Standards*, Proceeding of The First International Conference on Railway Technology: Research, Development and Maintenance, Las Palmas de Gran Canaria, Spain 2012, Wroclaw, Poland, pp. 133-134.
- [7] Zaharia N.L. *Determinarea stării de tensiune și deformații în structurile portante de cale ferată prin metoda elementelor finite cu ajutorul Ansys*, Simpozionul Național de Material Rulant de Cale Ferată, Nov. 26-27, 2012, Universitatea Politehnica București, Editura MatrixRom, București.
- [8] Vatulia G., Falendysh A., Orel Y., Pavliuchenkov M., *Structural Improvements in a Tank Wagon with Modern Software Packages*, 10th International Scientific Conference Transbaltica 2017: Transportation Science and Technology, Elsevier Procedia Engineering, 2017.
- [9] EN 12663-1:2010+A1:2014 Railway applications. Structural requirements of railway vehicle bodies. Locomotives and passenger rolling stock (and alternative method for freight wagons).
- [10] EN 12663-2:2010 Railway applications. Structural requirements of railway vehicle bodies. Freight wagons.

Addresses:

- Prof. Dr. Eng. Tiberiu Ștefan Mănescu, Babeș-Bolyai University, Faculty of Engineering, Piața Traian Vuia 1-4, 320085 Reșița, mts.tibi@yahoo.com
- Dr. Eng. Nicușor Laurențiu Zaharia, Romanian Railway Authority București, Calea Griviței 393, 010719 București, laurentiu@afer.ro (*corresponding author)
- Dr. Eng. Constantin Ioan Bărbintă, Babeș-Bolyai University, Faculty of Engineering, Piața Traian Vuia 1-4, 320085 Reșița constantin.barbinta@yahoo.ro