

# WHAT MAKES ROMANIANS TO BANK ON THEIR SMARTPHONES? DETERMINANTS OF MOBILE BANKING ADOPTION

IMOLA-ZSUZSÁNNA MOLDOVÁN<sup>1</sup>, ZSUZSA SĂPLĂCAN<sup>2</sup>

**ABSTRACT.** Mobile banking is becoming a priority for the banks and an increasingly popular banking channel for the consumers as well. According to the literature, despite a growing number of the mobile banking adoption studies worldwide, little attention has been paid to testing adoption models in Central and Eastern European countries. The aim of the study is to investigate the factors affecting mobile banking adoption in a country with relatively low mobile banking penetration rate. Based on an extended Technology Acceptance Model the present study aims to reveal the antecedents of the mobile banking adoption in Romania, and provide insightful conclusion for financial service institutions in mobile banking applications development. Our paper proposes and tests an extended model of the adoption intention of mobile banking applications. Besides the original perceived usefulness and perceived ease of use variables we also incorporated the social norm and some barrier factors such as perceived risk and technology anxiety. The results show, that the banks should consider seriously the consumer technology interface development challenges, including drivers and barriers of mobile banking adoption, because there are many other emerging non-bank players on financial service market fighting to fulfil the consumers' financial needs.

**Keywords:** mobile banking, Technology Acceptance Model, consumer behaviour, Romania

**JEL classification:** G21, O33, M39

---

<sup>1</sup> Babeş-Bolyai University, Faculty of Economics and Business Administration, imola.moldovan@yahoo.com

<sup>2</sup> Lecturer, Dr., Babeş-Bolyai University, Faculty of Economics and Business Administration, zszusa.pal@econ.ubbcluj.ro

**Recommended citation:** Moldovan, I-Z., Saplacan, Z., *What makes Romanians to bank on their smartphones? Determinants of mobile banking adoption*, *Studia UBB Negotia*, vol. 63, issue 1 (March), 2018, pp. 5-33.

## Introduction

The fundamental shift between the banking channels has started in the mid 1990's, the traditional channels have been gradually switched to self-service channels, such as ATMs or online banking, and later the mobile banking (Pikkarainen et al., 2004).

Riquelme and Rios (2010) define mobile banking as an electronic banking method, which offers electronic financial services to customers using mobile phone technology or other wireless devices. The Federal Reserve in their report entitled *Consumer and Mobile Financial Services 2015* refer to the mobile banking as a service which allows users to receive information about their bank account and make financial transactions through their mobile phone. This can be conducted by accessing the financial institute's website from the phone's browser, through text messages or using a smartphone application. In the present paper mobile banking denotes the smartphone applications developed by the banks, through which users can access their bank accounts and make different transactions (check the balance, transfer money, etc) (Federal Reserve Board, 2015).

The ascending trend of mobile technology development and the adoption of these technologies and devices by consumers make the mobile banking service topic crucial for banks. The traditional mobile phones, however, did not prove to be the most suitable device for mobile banking, due to their small screen and limited function. But in 2007 Apple launched the first iPhone and this brought a new era for mobile banking, which is developing more and more today. Along with the smartphone the AppStore was born, where the applications developed by banks were uploaded. The iPhone was followed by other smartphone brands on the market, such as Samsung or HTC. According to Statista (2016), the number of smartphone users in the present exceeds 2 billion worldwide, and foreseeably this number will grow to 2.6 billion by 2019.

When analysing the mobile banking penetration, KPMG in their *Mobile banking 2015* study predicted that, mobile banking penetration will increase to 1 billion users by 2017 and by 2019 it will reach 1.8 billion users worldwide. In the same report was stated, that for the majority of banks the mobile channel hosts the most transactions. The adoption rates are highest in developing countries, such as China and India, where 60-70% of bank customers use the mobile channel. In Europe at the end of the year 2014, the average mobile banking penetration rate through the bank customers was 38%, exactly matching the UK's adoption rate. Globally, 40% of the bank customers are mobile banking users (KPMG, 2015). According to Statista's estimation (2017) in Romania the number of smartphone users reach 8.61 million in 2016, which means that almost every second Romanian citizen owns a smartphone, while the mobile internet users reach 9.37 million in 2017 (Statista, 2017a). When it comes to the mobile banking usage rate in Romania, according to ING survey (2015), Romania is in the last place, with only 25% of mobile device owners using mobile banking. On the other hand, the rate of those, who are planning to use the mobile banking in the next 12 months (and own a mobile device), is 33%, which makes Romania rise to the top. Considering these two rates and the high smartphone penetration, it can be predicted that there is a great potential in mobile banking in Romania.

Mobile banking is becoming a priority for the banks. Many studies have confirmed that banks are increasingly focusing on the mobile first concept by optimizing their websites for the mobile browsers, developing applications and making certain content available on the mobile platform sooner than on the other vehicles (Bain & Company, 2015). The reason behind these actions is that the mobile channel brings a lot of benefits for the banks. A bank can increase its efficiency by implementing an integrated channel strategy, which includes mobile banking. Thanks to the low transaction costs of the mobile channel, the bank could spare a considerably large sum of money; moreover, it could close poorly performing branches. In addition to efficiency increase, there is a revenue increasing potential in mobile banking as well, due to many reasons: the mobile channel expands the demographic footprint of the bank, it offers insight into the consumer expenditure (opportunity for

cross- and up-selling, providing better customer service, improving decision capabilities, etc), banks can drive customers to this channel by providing discount at retailer partners, they can also segment and target their customers much better, which leads to more efficient marketing campaigns (Deloitte, 2010). In Bain & Company's (2015) survey loyalty figures as a benefit as well, because of the fact, that the mobile application offers an easy, reliable and efficient experience, which has a much better impact on the consumer, than the experience gained at the branch or through the phone.

Mobile banking is becoming increasingly popular for the consumers as well. Bain & Company (2015) showed in their survey, that most age groups are using mobile banking more frequently than online banking. The largest shifts from online to mobile since 2013 happened in Netherlands, South Korea and China. The higher usage of the mobile channel correlates with lower branch usage, but it's not a one-to-one relationship (Bain & Company, 2015). Despite the fact, that in the last two years, the number of routine operations conducted through the mobile channel grew dramatically, the routine branch operation decreased rather slowly. This can be explained by the fact, that consumers need time to adapt to the new channel. That's why banks need to focus on teaching their consumers to take advantage of the application's benefits whenever they have the possibility to do so (Bain & Company, 2015).

Beside the opportunities delivered by technological development, the traditional banks face an intensifying market competition pressure coming from behalf of the fintech companies and other start-ups. Due to the increasing interest toward the mobile banking usage, both academic researchers and practitioners try to identify the drivers and barriers of the mobile banking adoption in different countries. The introduction of the smartphone-based mobile banking services has launched a second wave of mobile banking adoption studies (Moser, 2015). Despite the increasing number of mobile banking related consumer behaviour studies, there is a need for further investigation, especially regarding the barriers of the adoption and the geographic area covered by studies (Baptista and Oliveira, 2016).

The aim of the study is to investigate the factors affecting mobile banking adoption in a country with low mobile banking penetration rate. Based on an extended Technology Acceptance Model (Davis, 1989) the present study aims to reveal the antecedents (drivers and barriers) of the mobile banking adoption in Romania, and provide insightful conclusion for financial service institutions in mobile banking application's development.

## **1. Literature Review**

### **1.1. The mobile banking acceptance**

The original Technology Acceptance Model (TAM) (Davis, 1989) has been used in many new technology-related researches, including studies of mobile banking acceptance (Aboelmaged and Gebba, 2013; Akturan and Tezcan, 2012; Lee et al., 2007; Mortimer et al., 2015).

The TAM was developed and introduced by Fred D. Davis in 1986, based on Fishbein and Ajzen's Theory of Reasoned Action (TRA). The aim of TAM is to provide a general explanation of the determinants influencing the acceptance of the computer and to be able to explain the users' behaviour towards a wide range of technological and computer systems, while the model is both empirically and theoretically justified (Davis et al., 1989). According to Davis et al. (1989), the main objective of TAM is to provide a theoretical basis for examining the effects of external factors on internal beliefs, attitudes and intentions. In order to meet this goal, they identified a few fundamental variables based on earlier researches studying the cognitive and affective determinants of computer acceptance, then used the TRA model to establish the relationships among them (Davis et al., 1989). The TAM has been used by many researchers from different research areas and in all of the cases the model has been proven accurate.

Two fundamental variables of TAM are the perceived usefulness and the perceived ease of use, which have a primary influence on the computer acceptance behaviour (Davis et al, 1989). The model presumes

that the actual use of a technology is determined by the behavioural intention to use that technology, and this intention is influenced by the attitude toward using the system and the perceived usefulness. If the consumer has a positive attitude towards using that technology, the intention to use will also be positive, so the consumer will most likely accept and use the technology (Davis et al, 1989). Venkatesh and Davis (2000) created the TAM2, which differs from TAM only in the independent variables added to the fundamental ones (for example subjective norm, experience, job relevance, result demonstrability etc). In TAM2 were examined the relationships between the new independent variables and the perceived usefulness.

Over the years, numerous researches have been conducted on mobile banking worldwide. It is a frequent research topic in the developed (South Korea, France) and developing countries (African countries, India) as well. In the developed countries there is a continuous shift from the traditional channels to the self-service channels and for this phenomenon the Netherlands is a great example, since there has been a huge online to mobile shift from 2013 (Bain & Company, 2015). In the developing countries the financial services are delivered mostly through the mobile platform; since the branch infrastructure is not so developed, banks are focusing more on the mobile channel (Gupta, 2013).

In their research undertaken in South Korea, Lee et al. (2007) examined the factors influencing the adoption of mobile banking in, using the TAM, to which they added two new variables: trust and perceived risk. The study showed, that trust and perceived usefulness influence adoption directly, while perceived risk has an indirect influence on adoption (via trust). The results also revealed that trust has a stronger influence on adoption than perceived usefulness; therefore, every bank should focus on building trust within their customers. Riquelme and Rios (2010) studied the factors influencing the adoption of mobile banking among current users of internet banking in Singapore, adding the gender as a moderating variable. The survey's results showed that perceived usefulness has the strongest influence on adoption, followed by subjective norm and social risk. Perceived usefulness has a larger effect in case of female users, while

male users are more influenced by the relative advantage. Social norms influence the adoption of mobile banking more in case of females than males. Püschel et al. (2010) also proposed an extended TPB with elements from TAM, such as perceived ease of use, and other predictors. They found, that all the independent variables of the intention of adoption are significant, while the predictors of the attitude toward mobile banking usage are the relative advantage, the image, the trialability, the visibility, the results demonstrability of the results, the compatibility and the perceived ease of use of the application.

Another TAM-model based study was conducted by Akturan and Tezcan (2012) in Turkey, where they surveyed students who were not using mobile banking but were considered as potential future users. As a result, they found, that perceived usefulness, perceived social risk, perceived performance risk and perceived benefits have a direct influence on attitude, which is the main determinant of the mobile banking adoption intention. There was no significant relationship found between perceived ease of use and attitude, financial risk, time, security risk and attitude, perceived usefulness and intention to adopt. Ouyang (2012) investigated the factors influencing the adoption of mobile banking in Taiwan. He also used the TAM as a theoretical model, to which he added security anxiety and Internet trust as external variables. It was found that security anxiety and trust influence the perceived usefulness and perceived ease of use, therefore they predict the attitude and through it the intention towards adoption as well. As a result, it was concluded, that security anxiety and Internet trust are two significant indirect factors influencing the adoption of mobile banking.

Aboelmaged and Gebba (2013) used the TAM and the Theory of Planned Behaviour (TPB) models to examine the factors influencing the adoption of mobile banking among undergraduate and postgraduate students in Dubai. As a conclusion they found that attitude and subjective norm have a significant and positive effect on the adoption of mobile banking, while perceived usefulness and behavioural control don't influence the adoption. Furthermore, it was showed, that attitude is significantly influenced by perceived usefulness, but not affected by perceived ease of use. Finally, there was a significant and positive relationship between usefulness and ease of use. AlSoufi and Ali (2014)

analysed the factors influencing the adoption of mobile banking in Bahrain, using an extended TAM. It was found that perceived usefulness and perceived ease of use have the strongest influence on the intention to adopt. On the other hand, perceived cost and perceived risk don't have a direct effect on the adoption of mobile banking.

Another study, delivered by Mortimer et al. (2015) revealed that the impact of the perceived ease of use and the social influence on intention can be culture-specific. While in Australia the perceived ease of use, perceived usefulness and perceived risk are the primary determinants of mobile banking adoption, in Thailand the most important antecedent of the intention were the perceived usefulness, the perceived risk and the social influence.

Shaikh et al. (2015) use a combined TAP and TPB model in Pakistan. They found that attitude, subjective norm, perceived behavioural control and perceived usefulness are significant antecedents for the intention, while perceived usefulness and perceived ease of use for the attitude. Unexpectedly they did not find a significant relationship between the perceived risk and the attitude.

In addition to the researches on mobile banking based on TAM or TPB, there have been several others, which used a specific research model and introduced different variables (for example social and cultural factors, gender, personality traits etc). For example, Khraim et al. (2011) examined the factors influencing the adoption of mobile banking in Jordan. Six independent variables (self-efficacy, trialability, compatibility, complexity, risk and relative advantage) were introduced in the model, the effects of which were measured on technology acceptance. They found, that all the variables have a significant influence on the adoption of mobile banking. Chaouali et al. (2017) applied the theory of trying, and have found that the attitude toward adoption is a predictor for intention of use mobile banking, while the attitude itself is influenced by three attitude dimensions: attitude toward success, attitude toward failure, attitude toward learning. The attitude dimensions are predicted by consumers' general self-confidence and the cynicism.



**Table no. 1. Literature review**

<b>Authors</b>	<b>Dependent variable</b>	<b>Predictor</b>
Lee et al. (2007)	Adoption	Perceived usefulness*; Trust* (n)
	Trust (n)	Perceived risk*
	Perceived usefulness	Trust* (n)
Riquelme and Rios (2010)	Adoption	Usefulness*; Risk* (n); Social norms*
	Usefulness	Relative advantage* (n); Ease of use*
Püschel et al. (2010)	Intention	Subjective norm*; Attitude*; Perceived behavioural control*
	Attitude	Relative advantage* (n); Image* (n); Trialability* (n); Visibility* (n); Results demonstrability* (n); Compatibility* (n); Perceived ease of use*
	Perceived behavioural control	Technology facilitation condition* (n); Resource facilitation condition* (n); Self-efficacy* (n)
Khraim et al (2011)	Intention	Self-efficacy* (n); Trialability* (n); Compatibility* (n); Complexity* (n); Risk* (n); Relative advantage* (n)
Kesharwani and Bisht (2012)	Intention	Perceived usefulness*; Perceived ease of use; Perceived risk* (n); Social influences*
	Perceived risk	Trust* (n); Website design* (n); Social influences*
	Perceived ease of use	Website design* (n); Behavioural control*
	Perceived usefulness	Perceived ease of use*; Social influences*
Akturan and Tezcan (2012)	Intention	Attitude*; Perceived usefulness
	Attitude	Perceived usefulness*; Perceived ease of use; Perceived benefits* (n); Perceived social risk* (n); Perceiver performance risk* (n); Perceived financial risk (n); Perceived time risk (n); Perceived privacy risk (n)

<b>Authors</b>	<b>Dependent variable</b>	<b>Predictor</b>
Ouyang (2012)	Intention	Attitude*
	Attitude	Perceived usefulness*; Perceived ease of use*
	Perceived usefulness	Perceived ease of use*; Internet trust (n)
	Perceived ease of use	Internet trust* (n); Security anxiety (n)
Aboelmaged and Gebba (2013)	Adoption	Attitude*; Subjective norm*; Behavioural control; Perceived usefulness
	Attitude	Perceived usefulness*; Perceived ease of use
	Perceived ease of use	Perceived usefulness*
AlSoufi and Ali (2014)	Intention	Perceived usefulness*; Perceived ease of use*
	Perceived usefulness	Customer service* (n); Quality of service (n); Alternative (n); Efficient transaction* (n)
	Perceived ease of use	Efficient transaction* (n); Compatibility* (n); Self-efficacy* (n)
Hanafizadeh et al. (2014)	Intention	Ease of use*; Usefulness*; Cost* (n); Trust* (n); Credibility* (n); Compatibility* (n); Risk* (n); Interaction* (n)
Baptista and Oliveira (2015)	Intention	Performance expectancy* (n); Effort expectancy (n); Social influence; Facilitating conditions (n); Hedonic motivation* (n); Price value (n); Habit* (n)
Mortimer et al. (2015)	Intention	Perceived usefulness*; Perceived ease of use*/-; Need for interaction (n); Perceived risk* (n); Social influence -/*
Shaikh et al. (2015)	Intention	Attitude*; Subjective norm; Perceived behavioural control*; Perceived usefulness*
	Attitude	Perceived usefulness*; Perceived ease of use*; Perceived risk (n)
	Perceived behavioural control	Self-efficacy* (n); Regulatory support (n); Technology support* (n)

<b>Authors</b>	<b>Dependent variable</b>	<b>Predictor</b>
Baptista and Oliveira (2016) - metaanalysis	Intention	Performance expectancy* (n); Attitude*; Initial trust* (n); Perceived risk* (n)
	Performance expectancy (n)	Effort expectancy* (n)
	Attitude	Performance expectancy*(n)
	Initial trust (n)	Structural assurance* (n)
Laukkanen (2016)	Adoption	Value barrier* (n); Image barrier* (n); Gender * (n); Age* (n)
Chaouali et al. (2017)	Intention	Attitude toward adoption*
	Attitude toward adoption	Attitude toward success* (n); Attitude toward failure* (n); Attitude toward learning* (n)
	Attitude toward success / failure / learning (n)	General self-confidence* (n); Cynicism*

Notes: \* - significant connection; (n) new variable to TAM, TAM2 or TPB  
Source: authors' own construction

## 1.2. Research model and hypotheses

In the present research the TAM was adopted as a theoretical research model, based on the literature review (figure 1). The effect of perceived usefulness and perceived ease of use on attitude are investigated very often in mobile banking adoption, approximately one-third of all mobile banking adoption studies cite them (Shaikh and Karjaluoto, 2015). According to previous research, subjective norm, technology anxiety and perceived risk also influence the mobile banking adoption, therefore these variables were included in our research model. The perceived risk and the social influence or norms also have been researched widely, while anxiety is a less researched determinant in the literature.

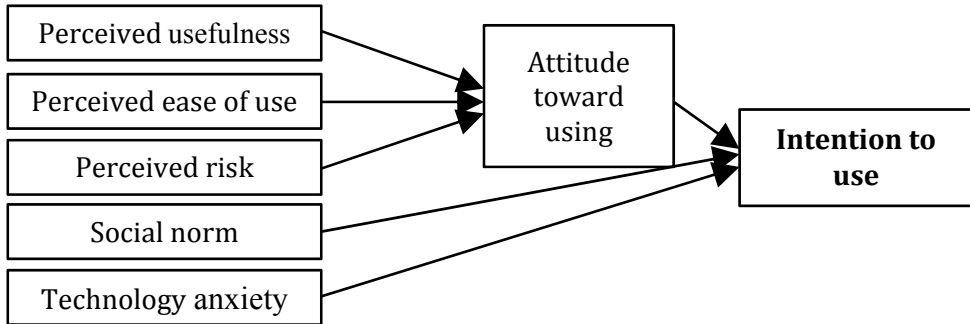

**Figure 1.** Proposed research model and the hypotheses

*Source: Authors' own construction*

### **Attitude toward use**

Allport (1935) defines attitude as “a mental and neural state of readiness, organized through experience, exerting a directive or dynamic influence upon the individual’s response to all objects and the situations with which they are related”. According to TAM, the attitude toward usage has a strong significant influence on behavioural intention (Davis et al., 1989), which means that a positive attitude toward mobile banking usage results in a higher willingness to adopt mobile banking apps. Most of the new technology adoption studies investigate the attitude as a predictor of technology adoption (Chaouali et al., 2017; Ouyang, 2012; Shaikh et al., 2015).

*H1. The attitude toward mobile banking usage has a positive significant influence on intention to use mobile banking apps.*

### **Subjective norm or social norm**

Based on the TRA model (which is the theoretical basis of TAM), Venkatesh and Davis (2000) introduced the social impact in the TAM2, which was represented by the subjective norm variable. According to definition, the subjective norm is a „person’s perception that most people who are important to him think he should or should not perform the behaviour in question” (Fishbein and Ajzen, 1975). The social norm

therefore is the effect of people with significant influence on consumer (for example family, friends, other important reference groups), based on which the consumer decides whether to use or not the service (Riquelme and Rios, 2010), in this case the mobile banking. Pedersen and Ling (2002, in Riquelme and Rios, 2010) suggested that external and social influence should be included in every model studying the intention of use, because these have a clear contribution to the adoption behaviour.

*H2. The social norm has a positive and significant effect on intention to use mobile banking apps.*

### **Technology anxiety**

As the new technologies are applied in many fields, it is important to investigate the consumers' ability and willingness to use these modern devices. „Anxiety is the unpleasant emotional reaction experienced by individuals in threatening situations.” (Schwarzer et al, 1982, in Cohen and Waugh, 1989). Computers present many opportunities for the perception of similar threats. Heinssen et al (1987, in Barbeite and Weiss, 2004) drew attention, that computer anxiety shouldn't be confused with the negative attitude towards computers, because the anxiety is one's emotional reaction to the usage of computers.

Technology anxiety is an extended version of computer anxiety and according to Scott and Rockwell (1997, in Shen et al., 2010) it is the psychological state of fear or anxiety experienced by consumers while using a new technology. Technology anxiety is seen as a general emotional distress, or the tendency of an individual to feel uneasy, apprehensive or phobic when using new technologies (Igarria and Iivari, 1995, in Shen et al., 2010). Meuter et al. (2003) found that technology anxiety influences the satisfaction, intention of use self-service technologies and the likelihood to spread positive word of mouth. In the case of mobile banking applications technology anxiety refers to the fear of smartphones or smartphone applications, which make the consumer feel insecure and incapable of using them properly, therefore can lead to a negative self-perception.

*H3. Technology anxiety is a significant barrier of mobile banking adoption. A higher level of anxiety causes a lower likelihood of mobile banking usage intention.*

### **Perceived usefulness**

In the definition of Davis et al (1989), perceived usefulness is the future user's subjective probability that the usage of the given technology system will increase his or her work performance in an organization. In the context of mobile banking, perceived usefulness refers to all operations, which save time, increase the efficiency of the service and the performance, but it can also refer to extremely useful attached services, such as paying the bills (Kesharwani and Bisht, 2012). Mobile banking operations, that support usefulness, can be: money transfer, balance check, online bank account statement, etc.

*H4. Perceived usefulness has a positive significant influence on attitude toward mobile banking usage.*

### **Perceived ease of use**

The perceived ease of use is a prospective user's expectation towards the usage of a technology system to require the least effort possible (Davis et al, 1989). As far as the perceived ease of use of mobile banking is concerned, it is essential that the application is easy to handle and learning the various bank operations is not difficult, neither takes much time. By integrating internal control (computer self-efficacy) and external control (facilitating conditions) into TAM, Venkatesh (2000) found several other factors, that explain the perceived ease of use.

*H5. Perceived ease of use has a positive significant influence on attitude toward mobile banking usage.*

### **Perceived risk**

Risk perception is usually arisen by the uncertainty related to the degree of discrepancies between consumer's expectations and actual behavioural outcome. If a technology fails to deliver its expected outcome, it causes loss to the user (Laukkanen and Kiviniemi, 2003). Perceptions of

risk are a strong explanatory factor in consumer behaviour, due to the fact that individuals pay more attention on avoiding the mistakes rather than maximizing the benefits from purchase (Mitchell, 1999, in Safeena et al., 2012).

In the case of mobile devices, the risk factor is crucial, as consumers' mobility increases the security risk arising from the infrastructure needed for wireless applications. At the same time, the risk associated with mobile applications is also high (Riquelme and Rios, 2010). If we talk about the risks related to the use of mobile banking applications, the extent of those is even greater, as there are possibilities of financial risk: the phone can be stolen and the application used by strangers or as a worst-case scenario, the bank account can be hacked due to an unsafe Internet connection, which leads to loss of money.

*H6. Perceived risk regarding the mobile banking usage has a negative impact on attitude toward use.*

## **2. Material and method**

Our study was conducted in Romania, where most of the banks provide mobile banking services for their clients. According to ING International Survey (Ipsos and ING, 2015) the penetration of mobile banking among mobile device users in Romania were only 25% in 2015, while in Europe this rate reached 53%. Thus, Romania can be considered interesting in terms of mobile banking adoption antecedents' research.

Data was collected by online questionnaire. The questionnaire includes three main sections: general banking behavioural questions, the latent constructs' scale questions from the model and demographic question. The latent variable scales were derived from previous studies, and were measure with five-point Likert scale (Table 2). In some cases, the statements were formulated both in indicative and conditional mood in order to address both the actual and potential users.

**Table 2. Measurement scales**

<b>Variables</b>	<b>Measuring items</b>	<b>Adapted from</b>
Perceived usefulness (PU)	Using mobile banking makes (would make) it easier and more convenient for me to carry out my tasks. (PU1)	Aboelmaged and Gebba (2013); Akturan and Tezcan (2012); Mortimer et al. (2015)
	Using mobile banking I can (would) save time. (PU2)	
	I think mobile banking is (would be) useful. (PU3)	
Perceived easiness of use (PEU)	I think that it is (would be) easy to use mobile banking to accomplish my banking tasks (PEU1)	Aboelmaged and Gebba (2013); Akturan and Tezcan (2012)
	It is (would be) easy to use mobile banking applications. (PEU2)	
	Learning to use mobile banking is (would be) easy and does not (would not) require a lot of effort. (PEU3)	
Social norm (SN)	People who are important to me think that I should use mobile banking apps. (SN1)	Riquelme and Rios (2010); Venkatesh and Davis (2000)
	People who influence my behaviour think that I should use mobile banking apps. (SN2)	
	I am (would be) trendy if I adopt (adopted) mobile app for banking transactions. (SN3)	
Perceived risk (PR)	When using (If I would use) mobile banking, I may lose money because my account information is hacked. (PR1)	Akturan and Tezcan (2012); Riquelme and Rios (2010)
	Conducting banking transactions on mobile phones is (would be) risky because one can easily lose or misplace the mobile phone. (PR2)	
	I think that using mobile banking is financially risky. (PR3)	
Technology anxiety (ANX)	Working with a mobile banking app makes (would make) me very nervous. (ANX1)	Barbeite and Weiss (2004)
	I get a sinking feeling when I think of using a mobile banking app (ANX2)	
	Using mobile banking apps makes (would make) me feel uncomfortable. (ANX3)	



Variables	Measuring items	Adapted from
Attitude toward using (ATT)	I think that using mobile banking is a good idea. (ATT1)	Akturan and Tezcan (2012)
	I think that using mobile banking for financial transactions is a wise idea. (ATT2)	
	I have positive opinion on mobile banking usage. (ATT3)	
Intention to use (INT)	I intend to use mobile banking in the next 3-6 months. (INT1)	Venkatesh and Davis (2000);
	I will use mobile banking as soon as possible. (INT2)	Aboelmaged and Gebba (2013)

*Source: Authors' own construction*

Data was collected by convenience sampling method. The questionnaire was spread online by email and facebook channels. Special concern was taken to reach the 35-44 age group, because the KPMG (2015) research stated that in Europe, the mean age of those who use mobile banking is about 39 years. Also, the high presence of the younger respondents in sample could be beneficial; Laukkanen (2016) found, that youngest people are more likely to adopt mobile banking technology than the older ones. A total 175 valid questionnaires were collected. The Table 3 summarizes the sample's socio-demographic characteristics.

**Table 3. The socio-demographic characteristics of the sample**

Demographics	N	Frequency
<b>Gender</b>	Male	72 41,14%
	Female	103 58,86%
<b>Age group</b>	17-24	80 45,71%
	25-34	46 26,29%
	35-44	36 20,57%
	45+	13 7,43%
<b>Education</b>	High school	43 24,57%
	University degree	104 59,43%
	Postgraduate	28 16,00%

<b>Demographics</b>		<b>N</b>	<b>Frequency</b>
<b>Home place</b>	Urban, more than 100 000 inhabitants	100	57,14%
	Urban, less than 100 000 inhabitants	56	32,00%
	Rural	19	10,86%
<b>Monthly gross income</b>	Less than 999 RON	60	34,29%
	1000-1999 RON	54	30,86%
	More than 2000 RON	61	34,86%

*Source: Authors' own construction*

### **3. Results and discussion**

Partial least square (PLS) modelling is a variance-based structural equation technique, and it is considered suitable in many research questions. It is useful to handle quite complex models based on a smaller dataset in comparison to covariance-based methods. The PLS is less restrictive than other models, especially regarding the sample size, data distribution and the complexity of the model.

A requirement towards the sample size is that the number of observations should be at least 10 higher than the maximum number of paths directed to a construct (Lowry and Gaskin, 2014). In our case, we have a maximum 3 of observed variables for a construct, thus a sample of 175 individuals is adequate (Gefen and Straub, 2005).

It is very convenient to use PLS because it develops both the measurement (outer) and the structural model (inner) paths simultaneously (Henseler et al., 2016). In the present study we used the SmartPLS3 program to analyse the model.

First, we analysed the measurement model of the latent variables. Our measurement model was a factor model, where the analysed psychological constructs were measured by Likert scale variables. The model satisfied all benchmarks for convergent validity (Table 4). All the loadings are above the 0.7 value, the average variance extracted (AVE) for all constructs were above 0.5 (Henseler et al., 2016) and all composite reliabilities were above 0.7 (Hair et al., 2010). Also, the Cronbach's Alpha has very high values, only one is situated below the 0.9 value (in case of SN). All the latent variables are measured properly by the proposed scales.

**Table 4. Construct Reliability of the measurement model**

<b>Constructs</b>	<b>Variable</b>	<b>Factor Loadings</b>	<b>AVE</b>	<b>Composite reliability</b>	<b>Cronbach's Alpha</b>
<b>Perceived ease of use - PEU</b>	PEU1	0.920	0.860	0.948	0.918
	PEU2	0.950			
	PEU3	0.911			
<b>Perceived risk - PR</b>	PR1	0.924	0.824	0.934	0.893
	PR2	0.915			
	PR3	0.884			
<b>Perceived usefulness - PU</b>	PU1	0.936	0.895	0.962	0.941
	PU2	0.939			
	PU3	0.963			
<b>Social norm - SN</b>	SN1	0.933	0.780	0.913	0.857
	SN2	0.953			
	SN3	0.749			
<b>Technology anxiety - ANX</b>	ANX1	0.912	0.845	0.942	0.908
	ANX2	0.906			
	ANX3	0.940			

Constructs	Variable	Factor Loadings	AVE	Composite reliability	Cronbach's Alpha
<b>Attitude toward mobile banking use - ATT</b>	ATT1	0.961	0.915	0.970	0.954
	ATT2	0.966			
	ATT3	0.942			
<b>Intention of mobile banking use - INT</b>	INT1	0.973	0.949	0.974	0.947
	INT2	0.975			

Source: Authors' own construction

The constructs also satisfied discriminant validity requirements based on Fornell and Larcker's (1981) criterion, that all square roots of AVE should be less than the correlation between the construct and the other constructs (see Table 5). In addition, all heterotrait-monotrait (HTMT) values were below the recommended threshold of 0.85 (situated between 0.030-0.792), supporting discriminant validity (Henseler, 2017).

**Table 5. Discriminant validity of the constructs – Fornell-Larcker Criterion**

	ANX	ATT	INT	PEU	PR	PU	SN
<b>ANX</b>	<b>0.919</b>						
<b>ATT</b>	-0.368	<b>0.957</b>					
<b>INT</b>	-0.452	0.679	<b>0.974</b>				
<b>PEU</b>	-0.315	0.743	0.535	<b>0.927</b>			
<b>PR</b>	0.432	-0.173	-0.228	-0.087	<b>0.908</b>		
<b>PU</b>	-0.193	0.749	0.537	0.715	0.015	<b>0.946</b>	
<b>SN</b>	-0.135	0.383	0.400	0.299	-0.025	0.358	<b>0.883</b>

Note: Square root of AVE (on diagonal) and factor correlation coefficients

Source: Authors' own construction

The outer model results show that the model has good construct reliability, convergence and discriminant validity, which means that the constructs are statistically well defined and can be used in path modelling.

In order to test our hypothesis, we performed a PLS analysis, with 5000 subsample bootstrapping. The goodness of fit for the model was satisfactory with a square root mean residual (SRMR) of 0.052, which is less than the recommended 0.08 maximum (Hu and Bentler, 1999). Taken together the indices presented above, the model fits the data well.

**Table 6. Structural model**

	<b>Path coefficient</b>	<b>Standard deviation</b>	<b>T Statistics</b>	<b>P values</b>
<b>Dependent variable: Intention of use</b>				
<b>R<sup>2</sup>=0.531</b>				
<b>ATT → INT</b>	0.528	0.066	8.040	0.000
<b>SN → INT</b>	0.167	0.054	3.097	0.002
<b>ANX → INT</b>	-0.235	0.071	3.325	0.001
<b>Dependent variable: Attitude R<sup>2</sup>=0.670</b>				
<b>PU → ATT</b>	0.469	0.094	4.992	0.000
<b>PEU → ATT</b>	0.394	0.098	4.037	0.000
<b>PR → ATT</b>	-0.145	0.053	2.736	0.006

*Source: Authors' own construction*

According to Hypothesis 1 and 2 the attitude towards usage respectively the subjective norm has a significant and positive effect on intention to adopt mobile banking applications, while in the Hypothesis 3 we expected that the technology anxiety has negative effect on mobile banking usage intention. All three hypotheses were confirmed, the attitude has the strongest explanation power on intention ( $\beta = 0.528$ ;  $p < 0.001$ ), followed by the negative effect of the technology anxiety ( $\beta = -0.235$ ;  $p = 0.001$ ) and the subjective norm ( $\beta = 0.167$ ;  $p = 0.002$ ). The independent variables together explain 53.1% of the variation in mobile banking usage intention.

Then, we hypothesised that perceived usefulness and the perceived ease of use have a positive impact on the attitude towards use of mobile banking services (H4 and H5), and the perceived risk of the usage has a negative effect on attitude towards the use (H3). The analysis confirms our hypotheses. The perceived usefulness ( $p < 0.001$ ), the perceived ease of use ( $p < 0.001$ ) and the perceived risk ( $p = 0.006$ ) explain statistically significantly the attitude towards mobile banking usage. According to the beta coefficients, a higher perception of usefulness ( $\beta = 0.469$ ) and ease of use ( $\beta = 0.394$ ) results in a stronger attitude, while stronger risk perception ( $\beta = -0.145$ ) reduce the intensity of the attitude towards mobile banking adoption. The results also show that PU is the most important construct in explaining ATT and the three determinants together explain 67% of the variation in attitude towards mobile banking usage (Figure 2).

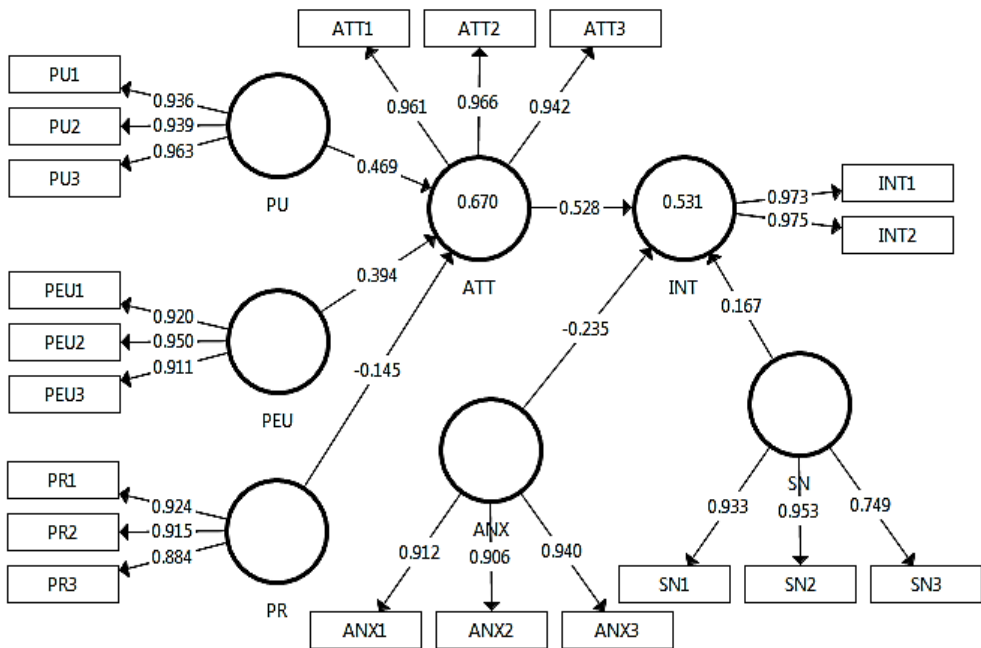

**Figure 2. Structural model results. Note: all the path coefficients are significant at least at  $p < 0.01$  level**

*Source: Authors' own construction*

The effect of the PEU and PU factors on attitude are investigated very often, approximately one-third of all mobile banking adoption studies investigate them (Shaikh and Karjaluoto, 2015), similarly the perceived risk is also a main issue in mobile banking adoption. Social influence or norms also have been researched widely, while anxiety is less researched. In line with literature (Baptista and Oliveira, 2016; Mortimer et al., 2015) we found significant relationship between ATT and INT, while PEU, PU and PR are significant predictors for the attitude. The influence of social interaction or social norm construct is not so obvious in the literature. Davis et al. (1989), in the original TAM study found that the social norm has no significant effect on intention, but recently the social influence issue is reintegrated in many studies regarding the mobile banking adoption (Shaikh and Karjaluoto, 2015) as the antecedent of the INT. In our case the SN is significant predictor for INT, but its effect is the lowest among predictors we investigated. The inclusion of the ANX variable is the major contribution of the proposed model. Similarly to other researches made on effect of the technology anxiety on self-service technology adoption (Meuter et al., 2003), we found a significant and negative relation between these two concepts.

From the managerial point of view our research provides some insightful results. First, the intention of adoption of mobile banking technologies depends on the consumers' attitudes towards these technologies, on social norms and on the degree of the anxiety they feel toward using technological devices in banking tasks. The technology anxiety is found to be significant for non-adoption and reduces the likelihood to use mobile banking. On the one hand a proper user interface could enhance the consumers' ability and willingness to use mobile banking apps, but on the other hand anxiety is a deeper personality dimension, which can be released by online video tutorials, or in face-to-face interactions in branches. The social norm also has a significant positive impact on adoption. This can be culturally determined, in certain cross-cultural comparisons the social interaction's effect differs among the countries. The significance of the social norm effect provides an opportunity for banks to stimulate the positive word of mouth by using different incentives. Also, in the case of services the word of mouth and the informal information sources reduce the perceived risk caused by intangibility and other service characteristics.

Second, the attitude has also a series of predictors. The perceived usefulness is the most important predictor for the attitude. If the banks can emphasize the main advantages of the mobile banking technology, they can increase the usefulness perception and therefore the attitude. The usefulness means time-saving and convenience; thus, the mobile banking design should be seamless and always functional. Perceived ease of use is the second most important predictor for the attitude, and refers to the user experience the customer faces. User experience of the mobile banking apps differs from banks to banks, and there is a huge potential to acquire and retain customers by offering easy ways of banking. These two benefits (usefulness and easiness) should be integrated in communication strategy. The perceived risk is also a significant predictor for attitude, but in a negative way. However, the coefficient of the perceived risk is not so high than the coefficients of the perceived benefits; but news about vulnerability of the digital systems in front of hacker attacks can increase the importance of this issue. Furthermore, the risk does not refer only to the hacker attacks, it can occur even when the internet connection fails. Thus, the mobile banking companies also should handle perceived problems caused by third party providers. The emphasis is on the term „perceived” regarding the risk which means that a well-designed communication strategy and a high-quality service can reduce the risk perception of the actual and potential mobile banking clients.

#### **4. Conclusions**

The banks should consider seriously the consumer technology interface development challenges, including those regarding the mobile banking services, because there are many other emerging non-bank players on financial service market (telecom companies, social media platforms or fintech companies) which show high flexibility and adaptability with regard to meeting consumers' (financial) needs and have produced a more dynamic expansion than the banking industry in the last few years (PwC, 2014).



Mobile banking is an emerging purchase and access channel for a range of banking services, and also a commodity service offered by the banks. Present paper aims to capture the antecedents of the mobile banking adoption among Romanian consumers. According to the literature, despite an increasing number of the mobile banking adoption studies worldwide, little attention has been paid to testing adoption models in Europe in general, excepting the Scandinavian countries, and in Central and Eastern European countries, in particular (Baptista and Oliveira, 2016). Most of the studies have been undertaken in Asia, Middle East and Africa.

In our paper, based on TAM model, we proposed and tested an extended model of the adoption intention of mobile banking applications. Besides the original PU and PEU variables we also incorporated the social factor SN and we also captured the effect of some barrier factors such as perceived risk or technology anxiety.

The study has some limitations and further research agendas. The research was conducted in Romania which reduces the generalising potential, but it could be considered in countries with similar business context and banking market development. Also, additional determinants can be included in the study as well as moderating variables. For examples in our study we have not made differentiation between actual and potential mobile banking users. In any case, there is a huge potential in mobile banking adoption researches, whereas the market is dynamically increasing, the competition is dramatically intensifying and the companies are interested in understanding the determinants of mobile banking adoption and experience.

## REFERENCES

1. Aboelmaged, M.G. and Gebba, T.R. (2013), Mobile Banking Adoption : An Examination of Technology Acceptance Model and Theory of Planned Behavior, *International Journal of Business Research and Development*, Vol. 2 No. 1, pp. 35–50.
2. Akturan, U. and Tezcan, N. (2012), Mobile banking adoption of the youth market", *Marketing Intelligence and Planning*, Vol. 7 No.9, pp. 444–459.

3. Allport, G.W. (1935), Attitudes in C. Murchison (Ed.), *Handbook of Social Psychology*, Worcester: Clark University Press, pp. 798–844.
4. AlSoufi, A. and Ali, H. (2014), Customers' perception of M-banking adoption in Kingdom of Bahrain: an empirical assessment of an extended TAM model, *International Journal of Managing Information Technology*, Vol. 6 No. 1, pp. 1–13.
5. Bain & Company (2015), The future of banking. Customer behaviour and loyalty in retail banking, available at: <http://www.bain.com/publications/articles> (accessed on March 21<sup>st</sup>, 2016).
6. Baptista, G. and Oliveira, T. (2015), Understanding mobile banking: The unified theory of acceptance and use of technology combined with cultural moderators, *Computers in Human Behavior*, Vol. 50, pp. 418–430.
7. Baptista, G. and Oliveira, T. (2016), A weight and a meta-analysis on mobile banking acceptance research, *Computers in Human Behavior*, Vol. 63, pp. 480–489.
8. Barbeite, F.G. and Weiss, E.M. (2004), Computer self-efficacy and anxiety scales for an Internet sample: testing measurement equivalence of existing measures and development of new scales, *Computers in Human Behavior*, Vol. 20, pp. 1–15.
9. Chaouali, W., Souiden, N. and Ladhari, R. (2017), Explaining adoption of mobile banking with the theory of trying, general self-confidence, and cynicism, *Journal of Retailing and Consumer Services*, Vol. 35, pp. 57–67.
10. Cohen, B.A. and Waugh, G.W. (1989), Assessing computer anxiety, *Psychological Report*, Vol. 65, pp. 735–738.
11. Davis, F.D. (1989), Perceived Usefulness, Perceived Ease of Use, And User Acceptance of Information Technology, *MIS Quarterly*, Vol. 13 No. 3, pp. 319–340.
12. Davis, F.D., Bagozzi, R. P. and Warshaw, P. R. (1989), User Acceptance of Computer Technology: a Comparison of Two Theoretical Models, *Management Science*, Vol. 35 No. 8, pp. 982–1003.
13. Deloitte (2010), Mobile banking: A catalyst for improving bank performance Contents, available at: <https://www2.deloitte.com/ie/en/pages/operations/articles/mobile-banking-improving-performance.html> (accessed on March 21<sup>st</sup>, 2016).
14. Federal Reserve Board (2015), Consumers and Mobile Financial Services 2015, available at: <https://www.federalreserve.gov/econresdata/consumers-and-mobile-financial-services-report-201503.pdf> (accessed on March 21<sup>th</sup>, 2016).
15. Fishbein, M. and Ajzen, I. (1975), *Belief, Attitude, Intention, and Behavior: An Introduction to Theory and Research*, Reading, MA: Addison-Wesley.

16. Fornell, C. and Larcker, D. F. (1981), Structural Equation Models with Unobservable Variables and Measurement Error: Algebra and Statistics, *Journal of Marketing Research*, Vol. 18 No. 3, pp. 382–388.
17. Gefen, D. and Straub, D. (2005), A Practical Guide to Factorial Validity Using PLS-Graph: Tutorial and Annotated Example”, *Communications of the Association for Information Systems*, Vol. 16, available at: <http://aisel.aisnet.org/cais/vol16/iss1/5/> (accessed on May 15<sup>th</sup>, 2016).
18. Hair, J. F., Black, W. C., Babin, B. J. and Anderson, R. E. (2010), *Multivariate Data Analysis* (Seventh Ed), Prentice Hall, Upper Saddle River, New Jersey.
19. Hanafizadeh, P., Behboudi, M., Abedini, A., Jalilvand, M. and Tabar, S. (2014), Mobile-banking adoption by Iranian bank clients, *Telematics and Informatics*, Vol. 31 No. 1, pp. 62–78.
20. Henseler, J. (2017), Bridging Design and Behavioral Research with Variance-Based Structural Equation Modeling, *Journal of Advertising*, Vol. 46 No. 1, pp. 178–192.
21. Henseler, J., Hubona, G. and Ash Ray, P. (2016), Using PLS path modelling in new technology research: updated guidelines, *Industrial Management and Data Systems*, Vol. 116 No. 1, pp. 2–20.
22. Hu, L. and Bentler, P. M. (1999), Cut-off criteria for fit indexes in covariance structure analysis: Conventional criteria versus new alternatives, *Structural Equation Modeling: A Multidisciplinary Journal*, Vol. 6 No. 1, pp. 1–55.
23. Ipsos and ING. (2015), ING International Survey - Mobile Banking, New Technologies and Financial Behaviour, available at: [https://www.economics.com/ing\\_international\\_surveys](https://www.economics.com/ing_international_surveys) (accessed on March 21<sup>st</sup> 2016).
24. Kesharwani, A. and Bisht, S.S. (2012), The impact of trust and perceived risk on internet banking adoption in India An extension of technology acceptance model, *International Journal of Bank Marketing*, Vol. 30 No. 4, pp. 303–322.
25. Khraim, H.S., Ellyan, Y., Shoubaki, A.L. and Khraim, A. S. (2011), Factors Affecting Jordanian Consumers’ Adoption of Mobile Banking Services, *International Journal of Business and Social Science*, Vol. 2 No. 20, pp. 96–105.
26. KPMG. (2015), Mobile Banking, available at: <https://www.kpmg.com/> (accessed on March 21<sup>st</sup> 2016).
27. Laukkanen, T. (2016), Consumer adoption versus rejection decisions in seemingly similar service innovations: The case of the Internet and mobile banking, *Journal of Business Research*, Vol. 69 No. 7, pp. 2432–2439.
28. Laukkanen, T. and Kiviniemi, V. (2003), The role of information in mobile banking resistance, *International Journal of Bank Marketing*, Vol. 28 No. 5, pp. 372–388.

29. Lee, K.S., Lee, H.S. and Kim, S.Y. (2007), Factors Influencing the Adoption Behavior of Mobile Banking: A South Korean perspective”, *Journal of Internet Banking and Commerce*, Vol. 12 No. 2, pp. 2–9.
30. Lowry, P.B. and Gaskin, J. (2014), Partial Least Squares ( PLS ) Structural Equation Modeling ( SEM ) for Building and Testing Behavioral Causal Theory: When to Choose It and How to Use It, *IEEE Transactions on Professional Communication*, Vol. 57 No. 2, pp. 123–146.
31. Meuter, M.L., Ostrom, A.L., Bitner, M.J. and Roundtree, R. (2003), The influence of technology anxiety on consumer use and experiences with self-service technologies, *Journal of Business Research*, Vol. 56, pp. 899–906.
32. Mortimer, G., Neale, L., Hasan, S.F.E. and Dunphy, B. (2015), Investigating the factors influencing the adoption of m-banking: a cross cultural study, *International Journal of Bank Marketing*, Vol. 33 no. 4, pp. 545–570.
33. Moser, F. (2015), Mobile Banking - A fashionable concept or an institutionalized channel in future retail banking? Analyzing patterns in the practical and academic mobile banking literature, *International Journal of Bank Marketing*, Vol. 33 No. 2, pp. 162–177.
34. Ouyang, Y. (2012), A use intention survey of mobile banking with smart phones an integrated study of security anxiety - Internet trust and TAM, *Innovative Marketing*, Vol. 8 No. 1, pp. 15–20.
35. Pikkarainen, T., Pikkarainen, K., Karjaluoto, H. and Pahnla, S. (2004), Consumer acceptance of online banking : an extension of the technology acceptance model, *Internet Research*, Vol. 14 No. 3, pp. 224–235.
36. Püschel, J., Mazzon, J.A. and Hernandez, J.M.C. (2010), Mobile banking: Proposition of an integrated adoption intention framework, *International Journal of Bank Marketing*, Vol. 28 No. 5, pp. 389–409.
37. PwC. (2014), The future shape of banking, available at: <https://www.pwc.com/gx/en/financial-services/publications/assets/pwc-the-future-shape-of-banking.pdf> (accessed on March 21<sup>st</sup> 2016).
38. Riquelme, H.E. and Rios, R.E. (2010), The moderating effect of gender in the adoption of mobile banking”, *International Journal of Bank Marketing*, Vol. 28 No. 5, pp. 328–341.
39. Safeena, R., Date, H., Kammani, A. and Hundewale, N. (2012), Technology Adoption and Indian Consumers: Study on Mobile Banking”, *International Journal of Computer Theory and Engineering*, Vol. 4 No. 6, pp. 1020–1024.
40. Shaikh, A.A., Glavee-Geo, R. and Karjaluoto, H. (2015), An Empirical Investigation of Mobile Banking Services Adoption in Pakistan, *International Journal of Social, Behavioral, Economic, Business and Industrial Engineering*, Vol. 9 No. 11, pp. 3676–3684.

41. Shaikh, A.A. and Karjaluoto, H. (2015), Mobile banking adoption: A literature review, *Telematics and Informatics*, Vol. 32 No. 1, pp. 129–142.
42. Shen, Y., Huang, C., Chu, C. and Hsu, C. (2010), A benefit – cost perspective of the consumer adoption of the mobile banking system”, *Behaviour and Information Technology*, Vol. 29 No. 5, pp. 497–511.
43. Statista (2016), Number of smartphone users worldwide from 2014 to 2019 (in millions), available at: <http://www.statista.com/statistics/330695> (accessed on March 21<sup>st</sup> 2016).
44. Statista (2017a), Forecast of mobile internet user numbers in Romania from 2014 to 2021, available at: <https://www.statista.com/statistics/567283/predicted-number-of-mobile-internet-users-in-romania/> (accessed on June 6<sup>th</sup> 2017).
45. Statista (2017b), Forecast of smartphone user numbers in Romania from 2014 to 2021, available at: <https://www.statista.com/statistics/566182/predicted-number-of-smartphone-users-in-romania/> (accessed on June 6<sup>th</sup> 2017).
46. Venkatesh, V. and Davis, F. D. (2000), A Theoretical Extension of the Technology Acceptance Model: Four Longitudinal Field Studies, *Management Science*, vol. 46 No. 2, pp. 186–204.

